



US 20180130953A1

(19) **United States**

(12) **Patent Application Publication**
SONG et al.

(10) **Pub. No.: US 2018/0130953 A1**

(43) **Pub. Date: May 10, 2018**

(54) **ORGANIC COMPOUND, AND ORGANIC LIGHT EMITTING DIODE AND ORGANIC LIGHT EMITTING DISPLAY DEVICE INCLUDING THE SAME**

C07D 487/04 (2006.01)

C07D 403/10 (2006.01)

(52) **U.S. Cl.**

CPC *H01L 51/0071* (2013.01); *C07D 491/048* (2013.01); *H01L 51/0072* (2013.01); *H01L 51/5016* (2013.01); *C07D 487/04* (2013.01); *C07D 403/10* (2013.01); *H01L 51/0067* (2013.01); *C07D 495/04* (2013.01)

(71) Applicant: **LG Display Co., Ltd.**, Seoul (KR)

(72) Inventors: **In-Bum SONG**, Seoul (KR); **Chun-Ki KIM**, Seoul (KR)

(73) Assignee: **LG Display Co., Ltd.**, Seoul (KR)

(21) Appl. No.: **15/794,632**

(22) Filed: **Oct. 26, 2017**

(30) **Foreign Application Priority Data**

Oct. 31, 2016 (KR) 10-2016-0143282

Publication Classification

(51) **Int. Cl.**

H01L 51/00 (2006.01)

C07D 491/048 (2006.01)

C07D 495/04 (2006.01)

(57) **ABSTRACT**

The present invention provides an organic compound for an organic light emitting diode. An example of the organic compound is represented by:

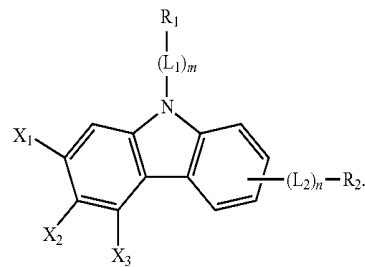

400

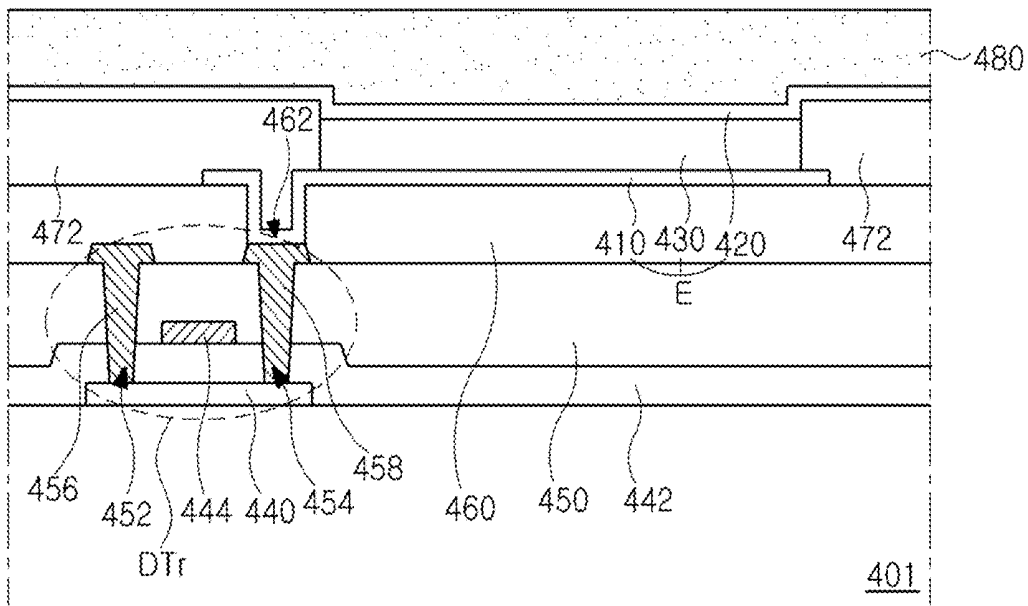

FIG. 1

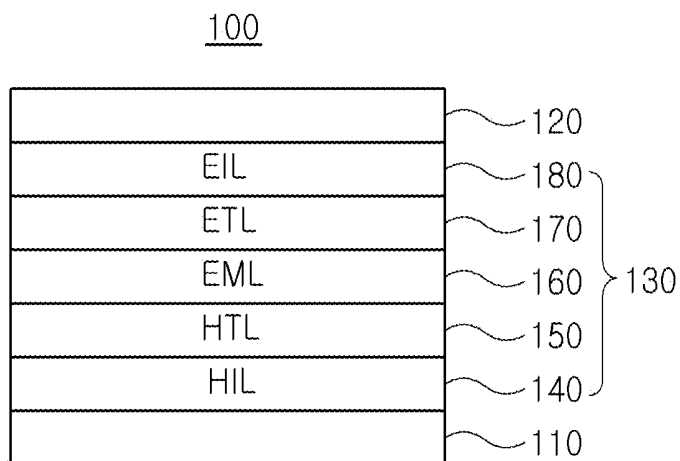

FIG. 2

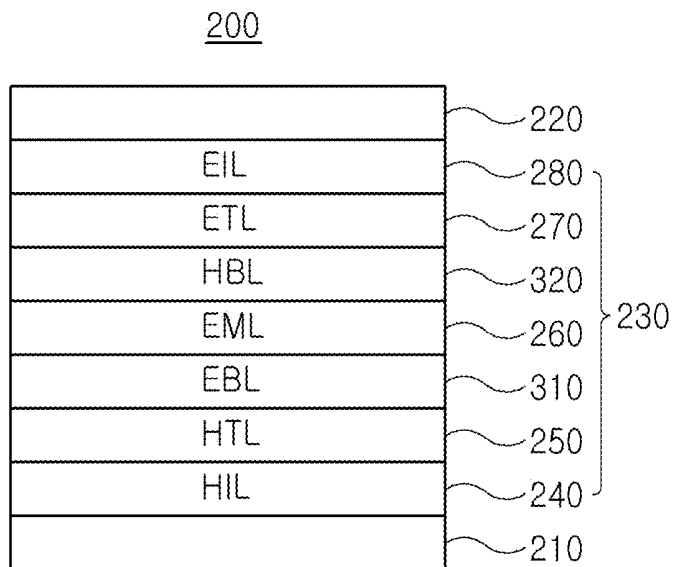
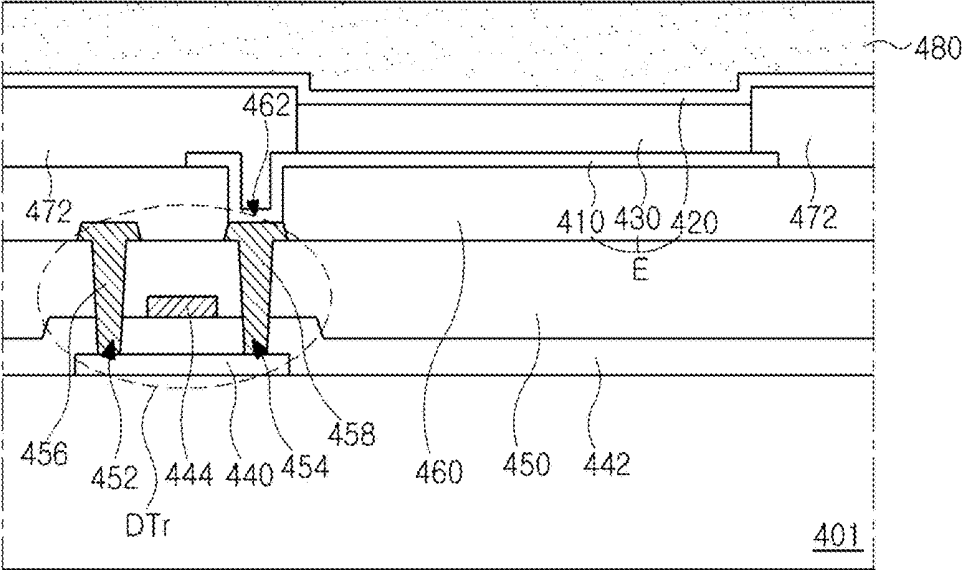

FIG. 3

400



**ORGANIC COMPOUND, AND ORGANIC
LIGHT EMITTING DIODE AND ORGANIC
LIGHT EMITTING DISPLAY DEVICE
INCLUDING THE SAME**

CROSS-REFERENCE TO RELATED
APPLICATION

[0001] The present application claims priority to and the benefit of Korean Patent Application No. 10-2016-0143282 filed in the Republic of Korea on Oct. 31, 2016, which is hereby incorporated by reference in its entirety.

BACKGROUND OF THE INVENTION

Field of the Invention

[0002] Embodiments of the invention relate to an organic compound, and more particularly, to an organic compound being capable of improving an emitting efficiency, a durability and a lifetime of an organic light emitting diode and an organic light emitting display device.

Discussion of the Related Art

[0003] Recently, as requirements of a flat panel display device having a small occupied area have increased, an organic light emitting display (OLED) device including an organic light emitting diode have been technically developed. The OLED device may be referred to as an organic electroluminescent device (OELD).

[0004] The organic light emitting diode emits light by injecting electrons from a cathode as an electron injection electrode and holes from an anode as a hole injection electrode into an emitting material layer (EML), combining the electrons with the holes, generating an exciton, and transforming the exciton from an excited state to a ground state. A flexible substrate, for example, a plastic substrate, can be used as a base substrate where elements are formed. The OLED device can be operated at a voltage (e.g., 10V or below) lower than a voltage required to operate other display devices. Moreover, the OLED device has an excellent color purity. In addition, the OLED device has advantages in the viewing angle and the contrast ratio in comparison to the LCD device, and the organic light emitting diode may be formed on a flexible substrate, such as a plastic substrate.

[0005] An organic emitting layer of the OLED device may have a single-layered structure of an emitting material layer (EML). Alternatively, to improve an emitting efficiency, the organic emitting layer may have a multi-layered structure. For example, the organic emitting layer may include a hole injection layer (HIL), a hole transporting layer (HTL), the EML, an electron transporting layer (ETL) and an electron injection layer (EIL).

[0006] To further improve the property or characteristic of the organic light emitting diode, a white emitting diode including at least two stacks is introduced. It may be referred to as a tandem structure organic light emitting diode. The tandem structure organic light emitting diode includes a charge generation layer (CGL) between adjacent stacks.

[0007] The process for fabrication of the related art OLED device is briefly described.

[0008] (1) A transparent conductive material, e.g., indium-tin-oxide (ITO) is deposited on a substrate to an anode.

[0009] (2) An organic material, e.g., dipyrzino[2,3-f:2',3'-h]quinoxaline-2,3,6,7,10,11-hexacarbonitrile (HATCN)

is deposited on the anode to form a hole injection layer (HIL) having a thickness of about 10 nm to 60 nm.

[0010] (3) An organic material, e.g., 4,4'-bis[N-(1-naphthyl)-N-phenylamino]-biphenyl (NPB) is deposited on the HIL to form a hole transporting layer (HTL) having a thickness of about 20 nm to 60 nm. In the phosphorescent organic light emitting diode, an exciton blocking layer such as an electron blocking layer (EBL) may be further formed on the HTL to efficiently trap the triplet exciton in an emitting material layer (EML).

[0011] (4) The EML including a host and a dopant is formed on the HTL (or the EBL). In the blue emission, 9,10-Bis(1-naphthyl)anthracene(a-ADN) may be used as the host, and 4,4'-bis[2-(4-(N,N-diphenylamino)phenyl)vinyl]biphenyl(DPAVBi) or diphenyl-[4-(2-[1,1;4,1]terphenyl-4-yl-vinyl)-phenyl]-amine(BD-1) may be used as the dopant. The dopant may have a weight % of 1 to 50, preferably 1 to 10. The EML may have a thickness of about 20 nm to 60 nm.

[0012] (5) An electron transporting layer (ETL) and an electron injection layer (EIL) are sequentially formed on the EML. Tris-(8-hydroxyquinoline aluminum (Alq3) may be used for the ETL, and LiF may be used for the ETL. In the phosphorescent organic light emitting diode, a hole blocking layer (HBL) may be further formed between the EML and the ETL to efficiently trap the triplet exciton in an emitting material layer (EML).

[0013] (6) A cathode is formed on the EIL.

[0014] As mentioned above, the organic light emitting diode emits light by injecting electrons from the cathode and holes from the anode into the EML, combining the electrons with the holes and generating an exciton. Since a single emitting material is used in the EML, the color purity, the emitting efficiency and the lifetime may be decreased. To improve the emitting efficiency and the lifetime, a host and a dopant are used for the EML. In the host-dopant system, the host generates an exciton and provide an energy into the dopant such that the light is efficiently emitted from the dopant. Namely, the energy, which is generated when the exciton is transited from an excited state to the ground state, is provided into the dopant via the host. As a result, in the host-dopant system, the energy is efficiently transferred into the dopant such that the exciton generation probability in the dopant is increased. Accordingly, the emitting efficiency of the organic light emitting diode is increased.

[0015] The emitting material is an important factor determining the emitting efficiency of the organic light emitting diode. In the host-dopant system, the host has strong effect on the emitting efficiency and the lifetime of the organic light emitting diode. Korean Patent No. 10-1404346 disclosed vinyl type norbornene polymer as a green phosphorescent host.

[0016] On the other hand, the emitting material in the organic light emitting diode should have good quantum efficiency, a high electron mobility and a high hole mobility. Since the related art host material has a wide band gap, the hole injection into the EML is delayed such that the driving voltage of the organic light emitting diode is increased. In addition, since the hole and the electron injected into the EML is unbalanced, the emission may be generated at an interface of the EML and adjacent layer such that the emitting efficiency and the lifetime are decreased.

[0017] Recently, a large-size organic light emitting display device having a high efficiency and a long lifetime is further required. Accordingly, a new emitting material having a high

thermal stability and a high hole-electron balance to provide high emitting efficiency and lifetime is required.

SUMMARY OF THE INVENTION

[0018] Accordingly, embodiments of the present invention are directed to an organic compound, an organic light emitting diode and an organic light emitting display (OLED) device including the same that substantially obviates one or more of the problems due to limitations and disadvantages of the related art.

[0019] An object of the present invention is to provide an organic compound having a high hole mobility, a high electron mobility and a high thermal stability.

[0020] An object of the present invention is to provide an organic compound being capable of improving the emitting efficiency and the color purity of the organic light emitting diode and the OLED device.

[0021] Additional features and advantages of the invention will be set forth in the description which follows, and in part will be apparent from the description, or may be learned by practice of the invention. The objectives and other advantages of the invention will be realized and attained by the structure particularly pointed out in the written description and claims hereof as well as the appended drawings.

[0022] To achieve these and other advantages and in accordance with the purpose of the present invention, as embodied and broadly described herein, an organic compound is represented by following Formula:

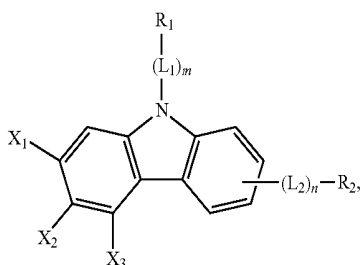

wherein R_1 is independently selected from the group consisting of substituted or non-substituted C_5 to C_{30} aryl group, substituted or non-substituted C_5 to C_{30} heteroaryl group, substituted or non-substituted C_6 to C_{30} arylalkyl group, substituted or non-substituted C_6 to C_{30} hetero-arylalkyl group, non-substituted C_6 to C_{30} aryloxy group and substituted or non-substituted C_6 to C_{30} hetero-aryloxy group, and R_2 is independently selected from the group consisting of hydrogen, deuterium, tritium, substituted or non-substituted C_5 to C_{30} aryl group, substituted or non-substituted C_5 to C_{30} heteroaryl group, substituted or non-substituted C_6 to C_{30} arylalkyl group, substituted or non-substituted C_6 to C_{30} hetero-arylalkyl group, non-substituted C_6 to C_{30} aryloxy group and substituted or non-substituted C_6 to C_{30} hetero-aryloxy group, wherein each of L_1 and L_2 is independently selected from the group consisting of substituted or non-substituted C_1 to C_{30} alkylene group, substituted or non-substituted C_3 to C_{30} cyclo-alkylene group, substituted or non-substituted C_5 to C_{30} arylene group, substituted or non-substituted C_4 to C_{30} heteroarylene group, substituted or non-substituted C_6 to C_{30} arylalkylene group, substituted or non-substituted C_6 to C_{30} hetero-arylalkylene group, substi-

tuted or non-substituted C_6 to C_{30} aryloxy group and substituted or non-substituted C_6 to C_{30} hetero-aryloxy group, and each of m and n is 0 or 1, and wherein X_2 with one of X_1 and X_3 forms a C_4 to C_{30} homo fused-ring or a C_4 to C_{30} hetero fused-ring, and the other one of X_1 and X_3 is selected from the group consisting of hydrogen, deuterium, tritium, substituted or non-substituted C_1 to C_{20} alkyl group, substituted or non-substituted C_1 to C_{20} alkoxy group, substituted or non-substituted C_5 to C_{30} aryl group and substituted or non-substituted C_5 to C_{30} heteroaryl group.

[0023] In another aspect, an organic light emitting diode comprises a first electrode; a second electrode facing the first electrode; and an organic layer between the first and second electrodes and including the above organic compound.

[0024] In another aspect, an organic light emitting diode comprises a first electrode; a second electrode facing the first electrode; and an organic layer between the first and second electrodes and including the above organic compounds and a dopant.

[0025] In another aspect, an organic light emitting display device comprises a substrate; the above organic light emitting diode; and a thin film transistor between the substrate and the organic light emitting diode and connected to the organic light emitting diode.

[0026] It is to be understood that both the foregoing general description and the following detailed description are exemplary and explanatory and are intended to provide further explanation of the invention as claimed.

BRIEF DESCRIPTION OF THE DRAWINGS

[0027] The accompanying drawings, which are included to provide a further understanding of the invention and are incorporated in and constitute a part of this specification, illustrate embodiments of the invention and together with the description serve to explain the principles of the invention.

[0028] FIG. 1 is a schematic cross-sectional view of an organic light emitting diode according to a first embodiment of the present invention.

[0029] FIG. 2 is a schematic cross-sectional view of an organic light emitting diode according to a second embodiment of the present invention.

[0030] FIG. 3 is a schematic cross-sectional view of an OLED device according to an embodiment of the present invention.

DETAILED DESCRIPTION OF THE EMBODIMENTS

[0031] Reference will now be made in detail to the preferred embodiments, examples of which are illustrated in the accompanying drawings. The term 'may' fully encompasses all the meanings of the term 'can'. All the components of an organic light emitting diode as well as display device including the organic light emitting diodes according to all embodiments of the present invention are operatively coupled and configured.

[0032] An emitting material used in an organic light emitting diode is required to have excellent properties, including a high quantum efficiency (emitting efficiency), a high hole mobility and a high electron mobility. In addition, the emitting material is required to be uniformly arranged (or dispersed) in an EML and stably induce emission. Moreover, the host in the host-dopant system is required to

have a molecular weight to be formed by a vacuum deposition. Further, the host is required to have high glass transition temperature and thermal decomposition temperature for thermal stability. The host is further required to have a high electrochemical stability for the lifetime and a good interface adhesive property with an adjacent layer.

[0033] An organic compound of the present invention capable of meeting the above requirements is represented in Formula 1.

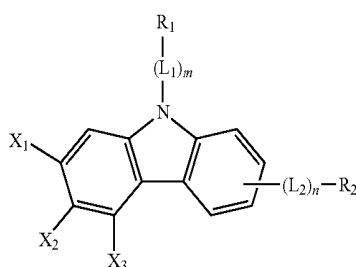

[Formula 1]

[0034] In Formula 1, R₁ is independently selected from the group consisting of substituted or non-substituted C₅ to C₃₀ aryl group, substituted or non-substituted C₅ to C₃₀ heteroaryl group, substituted or non-substituted C₆ to C₃₀ arylalkyl group, substituted or non-substituted C₆ to C₃₀ hetero-arylalkyl group, non-substituted C₆ to C₃₀ aryloxy group and substituted or non-substituted C₆ to C₃₀ hetero-aryloxy group, and R₂ is independently selected from the group consisting of hydrogen, deuterium, tritium, substituted or non-substituted C₅ to C₃₀ aryl group, substituted or non-substituted C₅ to C₃₀ heteroaryl group, substituted or non-substituted C₆ to C₃₀ arylalkyl group, substituted or non-substituted C₆ to C₃₀ hetero-arylalkyl group, non-substituted C₆ to C₃₀ aryloxy group and substituted or non-substituted C₆ to C₃₀ hetero-aryloxy group.

[0035] Each of L₁ and L₂ is independently selected from the group consisting of substituted or non-substituted C₁ to C₃₀ alkylene group, substituted or non-substituted C₃ to C₃₀ cyclo-alkylene group, substituted or non-substituted C₅ to C₃₀ arylene group, substituted or non-substituted C₄ to C₃₀ heteroarylene group, substituted or non-substituted C₆ to C₃₀ arylalkylene group, substituted or non-substituted C₆ to C₃₀ hetero-arylalkylene group, substituted or non-substituted C₆ to C₃₀ aryloxy group and substituted or non-substituted C₆ to C₃₀ hetero-aryloxy group, and each of “m” and “n” is 0 (zero) or 1.

[0036] X₂ with one of X₁ and X₃ forms a C₄ to C₃₀ homo fused-ring or a C₄ to C₃₀ hetero fused-ring. In this instance, the other one of X₁ and X₃ is selected from the group consisting of hydrogen, deuterium, tritium, substituted or non-substituted C₁ to C₂₀ alkyl group, substituted or non-substituted C₁ to C₂₀ alkoxy group, substituted or non-substituted C₅ to C₃₀ aryl group and substituted or non-substituted C₅ to C₃₀ heteroaryl group.

[0037] The term “substituted” encompasses embodiments in which the substituent may include halogen-substituted or non-substituted alkyl group, halogen-substituted or non-substituted alkoxy group, halogen, cyano group, carboxyl group, carbonyl group, amino group, alkylamino group, nitro group, hydrozyl group, sulfonate group, alkyl silyl group, alkoxy silyl group, cycloalkyl silyl group, aryl silyl

group, substituted or non-substituted aryl group or heteroaryl group, but it is not limited thereto.

[0038] The term “hetero”, which is used in heteroaryl, heteroarylene, and so on, means that at least one carbon atom in the aromatic ring or alicyclic ring is substituted by a heteroatom being selected from the group consisting of nitrogen atom (N), oxygen atom (O) and sulfur atom (S).

[0039] For example, R₁ may be independently selected from the group consisting of fused or non-fused homo-aromatic ring, such as phenyl, biphenyl, terphenyl, tetraphenyl, naphthyl, anthracenyl, indenyl, phenalenyl, phenanthrenyl, azulenyl, pyrenyl, fluorenyl, tetracenyl, indacenyl or spiro-fluorenyl, or fused or non-fused hetero-aromatic ring, such as pyrrolyl, pyridyl (or pyridinyl), pyrimidyl (pyrimidinyl), pyrazinyl, pyridazinyl, triazinyl, tetrazinyl, imidazolyl, pyrazolyl, indolyl, carbazolyl, benzocarbazolyl, dibenzocarbazolyl, indolocarbazolyl, indenocarbazolyl, quinolinyl, iso-quinolinyl, phthalazinyl, quinoxalinyl, cinnolinyl, quinazolinyl, phthalazinyl, benzoquinolinyl, benzoiso-quinolinyl, benzoquinazolinyl, benzoquinoxalinyl, acrydyl, phenanthrolinyl, furanyl, pyranyl, oxazinyl, oxazolyl, oxadiazolyl, triazolyl, dioxynyl, benzofuranyl, dibenzofuranyl, thio-pyranyl, thiazinyl, thiophenyl or N-substituted spiro-fluorenyl, and R₂ may be independently selected from the group consisting of hydrogen, fused or non-fused homo-aromatic ring, such as phenyl, biphenyl, terphenyl, tetraphenyl, naphthyl, anthracenyl, indenyl, phenalenyl, phenanthrenyl, azulenyl, pyrenyl, fluorenyl, tetracenyl, indacenyl or spiro-fluorenyl, or fused or non-fused hetero-aromatic ring, such as pyrrolyl, pyridyl (or pyridinyl), pyrimidyl (pyrimidinyl), pyrazinyl, pyridazinyl, triazinyl, tetrazinyl, imidazolyl, pyrazolyl, indolyl, carbazolyl, benzocarbazolyl, dibenzocarbazolyl, indolocarbazolyl, indenocarbazolyl, quinolinyl, iso-quinolinyl, phthalazinyl, quinoxalinyl, cinnolinyl, quinazolinyl, phthalazinyl, benzoquinolinyl, benzoiso-quinolinyl, benzoquinazolinyl, benzoquinoxalinyl, acrydyl, phenanthrolinyl, furanyl, pyranyl, oxazinyl, oxazolyl, oxadiazolyl, triazolyl, dioxynyl, benzofuranyl, dibenzofuranyl, thio-pyranyl, thiazinyl, thiophenyl or N-substituted spiro-fluorenyl.

[0040] For example, R₁ may be independently selected from the group consisting of phenyl, biphenyl, terphenyl, where each benzene ring is connected in a meta-position or a para-position, fluorenyl, spiro-fluorenyl, benzothiophenyl, dibenzothiophenyl, benzofuranyl, dibenzofuranyl, pyrrolyl, pyridinyl, pyrimidinyl, pyrazinyl, pyridazinyl, triazinyl, tetrazinyl, imidazolyl, pyrazolyl, indolyl, carbazolyl, benzocarbazolyl, dibenzocarbazolyl, indolocarbazolyl, indenocarbazolyl, benzofurano-carbazolyl, benzothieno-carbazolyl, quinolinyl, iso-quinolinyl, phthalazinyl, quinoxalinyl, cinnolinyl, quinazolinyl, benzoquinolinyl, benzoiso-quinolinyl, benzoquinazolinyl, spiro-carbazolyl and benzoquinoxalinyl, and R₂ may be independently selected from the group consisting of phenyl, biphenyl, terphenyl, where each benzene ring is connected in a meta-position or a para-position, fluorenyl, benzothiophenyl, dibenzothiophenyl, benzofuranyl, dibenzofuranyl, pyrrolyl, pyridinyl, pyrimidinyl, pyrazinyl, pyridazinyl, triazinyl, imidazolyl, pyrazolyl, indolyl, carbazolyl, benzocarbazolyl, dibenzocarbazolyl, indolocarbazolyl, indenocarbazolyl, benzofurano-carbazolyl, benzothieno-carbazolyl, quinolinyl, iso-quinolinyl, phthalazinyl, quinoxalinyl, cinnolinyl, quinazolinyl, benzoquinolinyl, benzoiso-quinolinyl, benzoquinazolinyl, spiro-carbazolyl and benzoquinoxalinyl.

[0041] R_1 may be selected from the group consisting of spiro-fluorenyl, phenyl, biphenyl, and R_2 may be selected from the group consisting of hydrogen, carbazole and fused carbazole. In this instance, the carbazole or the fused carbazole may be substituted by phenyl or biphenyl, and the fused ring of the fused carbazole may include oxygen atom or sulfur atom.

[0042] Each of L1 and L2 may be an aromatic linker. For example, each of L1 and L2 may be independently selected from the group consisting of substituted or non-substituted C5 to C30 arylene group, substituted or non-substituted C4 to C30 heteroarylene group, substituted or non-substituted C6 to C30 arylalkylene group, substituted or non-substituted C6 to C30 hetero-arylalkylene group, substituted or non-substituted C6 to C30 aryloxylyene group and substituted or non-substituted C6 to C30 hetero-aryloxylyene group.

[0043] Each of L1 and L2 may be independently selected from the group consisting of phenylene, biphenylene, terphenylene, tetraphenylene, indenylene, naphthylene, azulenylylene, indacenylene, acenaphthylene, fluorenylylene, spiro-fluorenylylene, phenalenylene, phenanthrenylene, anthracenylylene, fluoranthrenylene, triphenylenylene, pyrenylene, chrysenylene, naphthacenylylene, picenylene, perylenylene, pentaphenylene, hexacenylylene, pyrrolylene, imidazolylene, pyrazolylene, pyridinylene, pyrazinylene, pyrimidinylene, pyridazinylene, isoindolylene, indolylene, indazolylene, purinylene, quinolinylene, isoquinolinylene, benzoquinolinylene, phthalazinylene, naphthyridinylene, quinoxalinylene, quinazolinylene, benzo-isoquinolinylene, benzoquinazolinylene, benzoquinoxalinylene, cinnolinylene, phenanthridinylene, acridinylene, phenanthroli-nylene, phenazinylene, benzoxazolylene, benzimidazolylene, furanylylene, benzofuranylylene, thiophenylylene, benzothiophenylylene, thiazolylene, isothiazolylene, benzothiazolylene, isoxazolylene, oxazolylene, triazolylene, tetrazolylene, oxadiazolylene, triazinylene, dibenzofuranylylene, dibenzothiophenylylene, carbazolylene, benzocarbazolylene, dibenzocarbazolylene, indolocarbazolylene, indenocarbazolylene, imidazopyrimidinylene and imidazopyridinylene.

[0044] X1 and X2 or X2 and X3 may form a fused-ring, e.g., a C4 to C30 homo fused-ring or a C4 to C30 hetero fused-ring, connected to the carbazole core. In this instance, when a number of the fused-ring by X1 and X2 or X2 and X3 is increased, the conjugation length of the organic compound is increased such that the energy band gap of the organic compound is decreased. Accordingly, the number of fused-ring may be 1 or 2.

[0045] The fused-ring by X1 and X2 or X2 and X3 may be one of a homo fused-ring, such as benzene ring, naphthalene ring, pentalene ring, indene ring, azulene ring or heptalene ring, and a hetero fused ring, such as pyrrole ring, furane ring, thiophene ring, imidazole ring, pyrazole ring, pyridine ring, (dihydro) oxazole ring, thiazole ring, oxadiazole ring, diazole ring, triazine ring, azepine ring, pyrazine ring, pyrimidine ring, pyridazine ring, quinoline ring, isoquinoline ring, indole ring, indolizine ring, pteridine ring, cinnoline ring, quinazoline ring, quinoxaline ring, quinazoline ring, quinolizine ring, naphthrydine ring, indazole ring, furine ring, pyrrolizine ring, phthalazine ring, pyran ring, benzofurane ring, chromene ring, isochromene ring or benzothiophene ring.

[0046] Since the organic compound of the invention includes a carbazole moiety, on which a side ring is fused, the thermal stability of the organic compound is increased.

In addition, an aromatic ring is directly or indirectly connected to the ring-fused carbazole moiety, and the hole transporting property and/or the electron transporting property of the organic compound are improved by the aromatic ring. Accordingly, the organic light emitting diode including the organic compound has advantages in the emitting efficiency and the color purity, and the charge injection property is improved such that the driving voltage is reduced. Moreover, in the organic light emitting diode including the organic compound, the charge balance in an organic layer is improved or optimized. As a result, the emission at the interface between the EML and adjacent layer is prevented such that the emitting efficiency and the lifetime are improved.

[0047] The organic compound may have excellent hole injection property or transporting property and good thermal stability. This organic compound is referred to as a first organic compound. The first organic compound may be used as a P-type host in an organic layer of the organic light emitting diode. The first organic compound is represented by Formula 2.

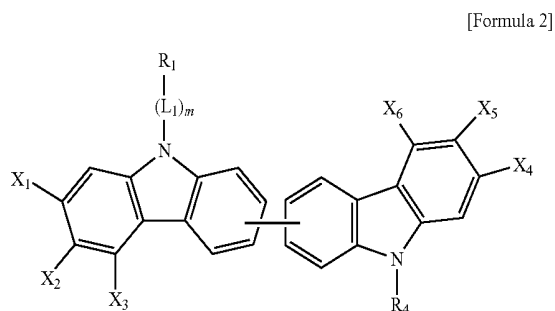

[0048] In Formula 2, each of R3 and R4 may be independently selected from the group consisting of hydrogen, deuterium, tritium, C5 to C30 aryl group, substituted or non-substituted C5 to C30 heteroaryl group, substituted or non-substituted C6 to C30 arylalkyl group, substituted or non-substituted C6 to C30 hetero-arylalkyl group, non-substituted C6 to C30 aryloxyly group and substituted or non-substituted C6 to C30 hetero-aryloxyly group, and X5 with one of X4 and X6 forms a C4 to C30 homo fused-ring or a C4 to C30 hetero fused-ring. Alternatively, each of X4 to X6 is independently connected to the carbon atom of the carbazole core without forming the fused-ring. In this instance, each of X4 to X6 may be hydrogen, deuterium, tritium, substituted or non-substituted C 1 to C20 alkyl group, substituted or non-substituted C 1 to C20 alkoxy group, substituted or non-substituted C5 to C30 aryl group or substituted or non-substituted C5 to C30 heteroaryl group. Each of L1, m, X1, X2 and X3 are same as defined in Formula 1.

[0049] In Formula 2, each of R3 and R4 is homo aryl group or heteroaryl group each having excellent hole transporting property. For example, each of R3 and R4 may be selected from the group consisting of phenyl, biphenyl, terphenyl, where each benzene ring is connected in a meta-position or a para-position, fluorenyl, spiro-fluorenyl, carbazolyl, benzocarbazolyl, dibenzocarbazolyl, indolocarbazolyl, indenocarbazolyl, benzofurano-carbazolyl, benzothieno-carbazolyl and spiro-carbazolyl.

[0050] X4 and X5 or X5 and X6 may form a fused-ring, e.g., a C4 to C30 homo fused-ring or a C4 to C30 hetero fused-ring, connected to the carbazole core. In this instance, when a number of the fused-ring by X4 and X5 or X5 and X6 is increased, the conjugation length of the organic compound is increased such that the energy band gap of the organic compound is decreased. Accordingly, the number of fused-ring may be 1 or 2.

[0051] The fused-ring by X4 and X5 or X5 and X6 may be one of a homo fused-ring, such as benzene ring, naphthalene ring, pentalene ring, indene ring, azulene ring or heptalene ring, and a hetero fused ring, such as pyrrole ring, furane ring, thiophene ring, imidazole ring, pyrazole ring, pyridine ring, (dihydro) oxazole ring, thiazole ring, oxadiazole ring, diazole ring, triazine ring, azepine ring, pyrazine ring, pyrimidine ring, pyridazine ring, quinoline ring, isoquinoline ring, indole ring, indolizine ring, pteridine ring, cinnoline ring, quinazoline ring, quinoxaline ring, quinazoline ring, quinolizine ring, naphthyridine ring, indazole ring, furine ring, pyrrolizine ring, phthalazine ring, pyran ring, benzofurane ring, chromene ring, isochromene ring or benzothiophene ring.

[0052] Since the first organic compound of the invention has an excellent hole transporting property, the first organic compound may be used as the P-type host in the EML. For example, the first organic compound of Formula 2, may be included in at least one of the EIL, the ETL, the EML and the EBL. Due to the first organic compound in the above organic layer, the hole injection and/or hole transporting property are improved, and the charge balance is improved. In addition, due to the first organic compound in the EBL, the exciton is trapped in the EML. As a result, the organic light emitting diode including the first organic compound has advantages in the driving voltage, the emitting efficiency, the lifetime, the thermal stability and the color purity.

[0053] The first organic compound of the present invention may be one of the compounds in Formula 3.

[Formula 3]

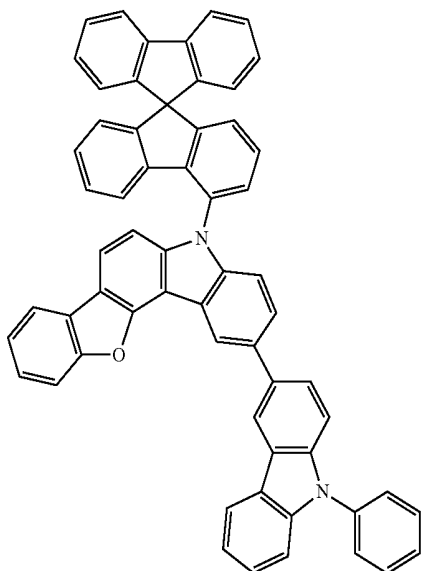

PPH1

-continued

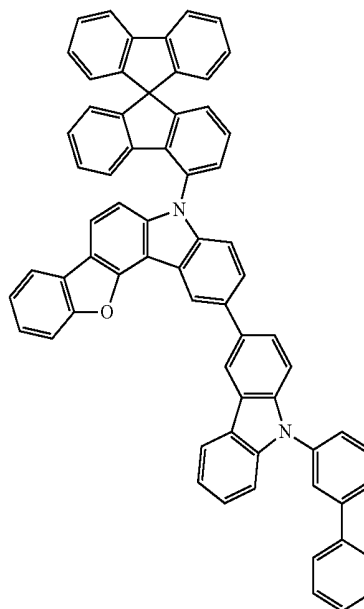

PPH2

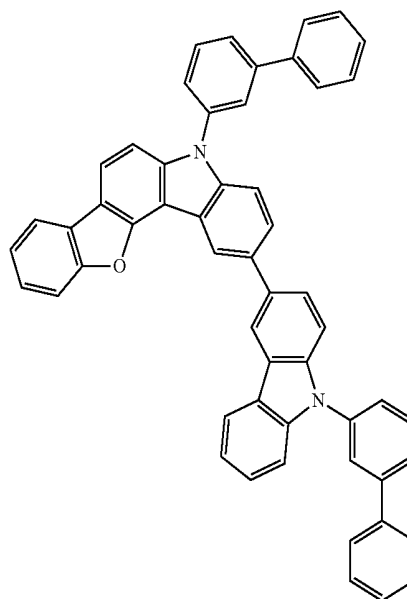

PPH3

-continued

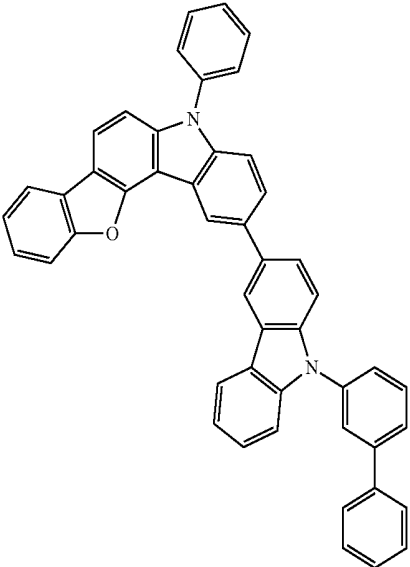

PPH4

-continued

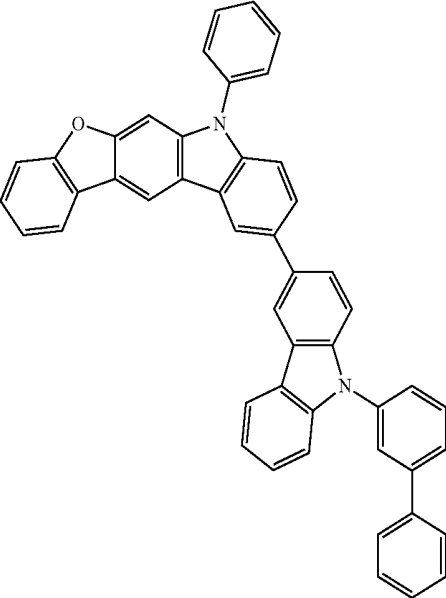

PPH6

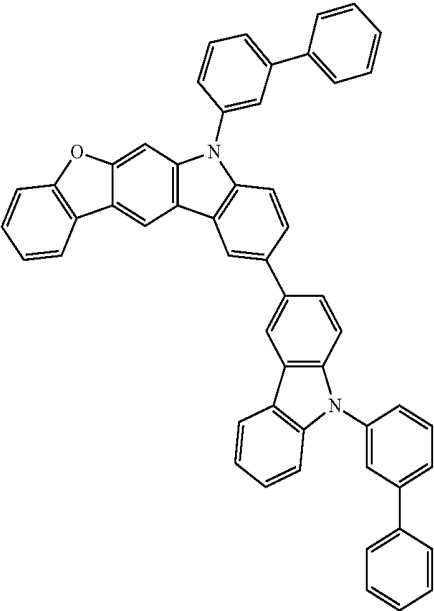

PPH5

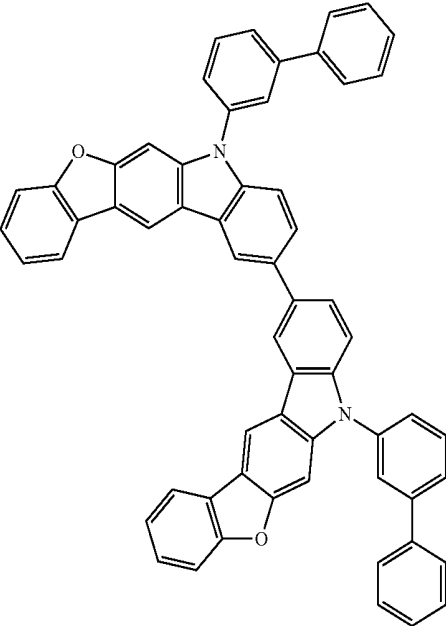

PPH7

-continued

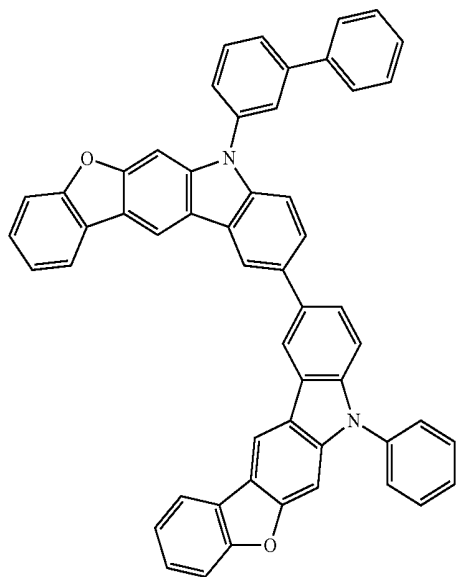

-continued

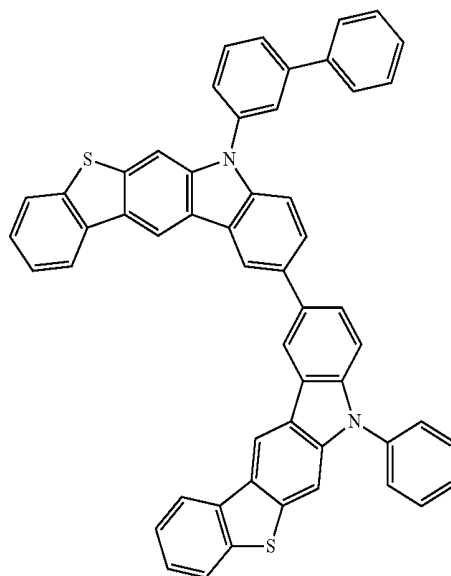

PPH8

PPH10

PPH11

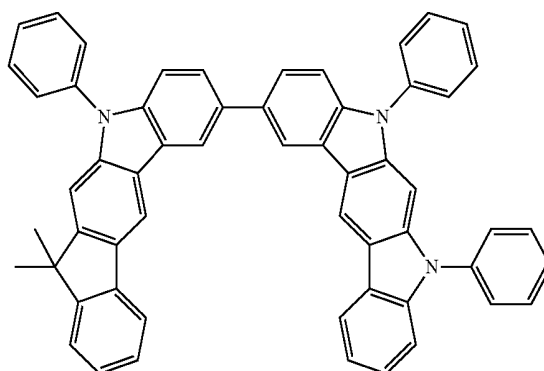

PPH9

PPH12

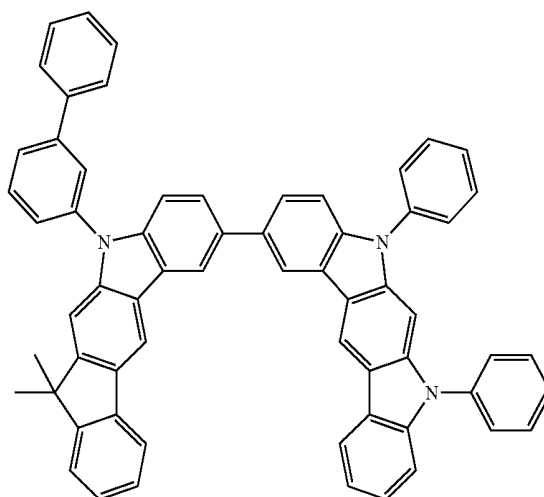
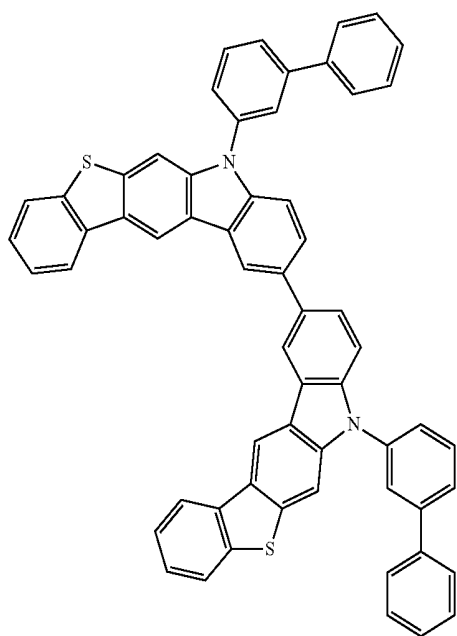

PPH12

-continued

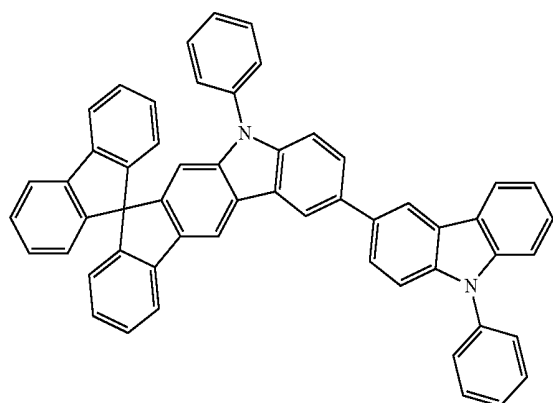

PPH13

-continued

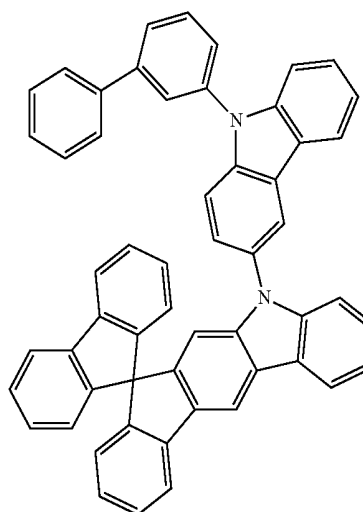

PPH16

PPH14

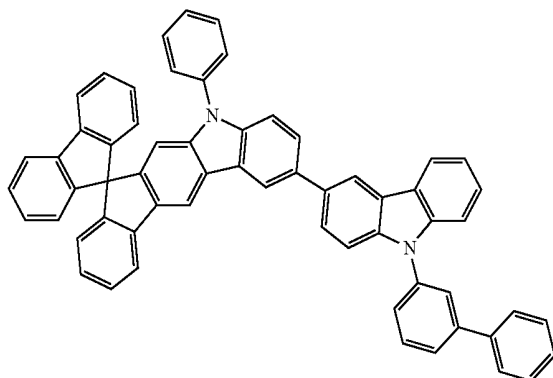

PPH15

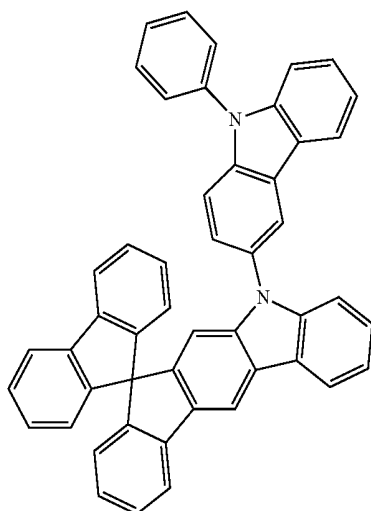

[0054] The first organic compound in Formula 2 or Formula 3 includes a first carbazole moiety, on which a side ring is fused, and a second carbazole moiety, on which one or two side ring may be fused, connected to the first carbazole moiety such that the hole transporting property is improved. The lowest unoccupied molecular orbital (LUMO) of the first organic compound is closer to the vacuum degree (0 eV) than a dopant, or the first organic compound has a wide energy band gap, i.e., a gap (difference) between the LUMO and the highest occupied molecular orbital (HOMO). In addition, the first organic compound has the triplet energy being greater than the dopant. Accordingly, when the first organic compound is used in the organic layer of the organic light emitting diode, the reverse-transition of the energy, which is transitioned from the host into the dopant, into the host is prevented such that the emitting efficiency is improved. The first organic compound may be included in at least one of the EIL, the ETL, the EML and the EBL of the organic light emitting diode.

[0055] The organic compound may have excellent properties in both hole injection (or transporting) and electron injection (transporting). In addition, the organic compound may have good thermal stability. This organic compound is referred to as a second organic compound. The second organic compound may be used as a N-type host or a bipolar host in an organic layer of the organic light emitting diode. The first organic compound is represented by Formulas 4a or 4b.

[Formula 4a]

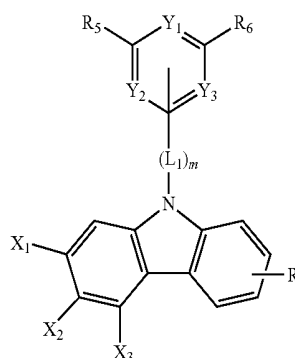

-continued

[Formula 4b]

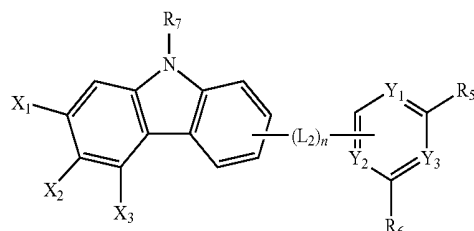

[0056] In Formulas 4a and 4b, each of R_5 to R_7 may be independently selected from the group consisting of hydrogen, deuterium, tritium, C_5 to C_{30} aryl group, substituted or non-substituted C_5 to C_{30} heteroaryl group, substituted or non-substituted C_6 to C_{30} arylalkyl group, substituted or non-substituted C_6 to C_{30} hetero-arylalkyl group, non-substituted C_6 to C_{30} aryloxy group and substituted or non-substituted C_6 to C_{30} hetero-aryloxy group. Each of Y_1 to Y_3 is independently N or CR_8 , and at least one of Y_1 to Y_3 is N. R_8 is selected from the group consisting of hydrogen, deuterium, tritium, C_5 to C_{30} aryl group, substituted or non-substituted C_5 to C_{30} heteroaryl group, substituted or non-substituted C_6 to C_{30} arylalkyl group, substituted or non-substituted C_6 to C_{30} hetero-arylalkyl group, non-substituted C_6 to C_{30} aryloxy group and substituted or non-substituted C_6 to C_{30} hetero-aryloxy group. X_1 to X_3 in Formulas 4a and 4B, L_1 and m in Formula 4a and L_2 and n in Formula 4b are the same as defined in Formula 1.

[0057] When a number of the ring in each of R_5 to R_7 is increased, the conjugation length of the organic compound is increased such that the energy band gap of the organic compound is decreased. Accordingly, the number of the ring in each of R_5 to R_7 may be 1 or 2, and beneficially the number of the ring in each of R_6 and R_7 may be 1.

[0058] For example, each of R_5 to R_7 may be 5-numbered atom ring to 7-numbered atom ring, and beneficially 6-numbered atom ring. Each of R_5 to R_7 may be independently selected from the group consisting of phenyl, pyrrolyl, imidazolyl, pyrazolyl, pyridinyl, pyrazinyl, pyrimidinyl, pyridazinyl, furanyl and thiophenyl.

[0059] A number of the ring in L_1 of Formula 4a and L_2 of Formula 4b is increased, the conjugation length of the organic compound is increased such that the energy band gap of the organic compound is decreased. Accordingly, the number of the ring in L_1 of Formula 4a and L_2 of Formula 4b may be 1 or 2, and beneficially 1. In addition, to improve the charge (i.e., hole or electron) injection and/or transporting property of the second organic compound, each of L_1 and L_2 may be 5-numbered atom ring to 7-numbered atom ring, and beneficially 6-numbered atom ring. Each of L_1 and L_2 may be independently selected from the group consisting of phenyl, pyrrolyl, imidazolyl, pyrazolyl, pyridinyl, pyrazinyl, pyrimidinyl, pyridazinyl, furanyl and thiophenyl.

[0060] As shown in Formulas 4a or 4b, in the second organic compound, the 6-atom hetero ring moiety, which has at least one nitrogen atom in the ring, is directly or indirectly connected to the fused carbazole moiety. For example, the 6-atom hetero ring moiety may be pyridine, pyrimidine or triazine, beneficially pyrimidine or triazine to further improve the electron injection property.

[0061] Since the second organic compound in Formulas 4a or 4b has excellent hole and electron injection/transporting properties, the second organic compound is used as the N-type host or the bipolar host in the organic layer. For example, the second organic compound may be included in at least one of the EIL, the ETL, the HBL, the HIL, the HTL, the EML and the EBL. Due to the second organic compound in the above organic layer, the hole injection/transporting property and electron injection/transporting property are improved, and the charge balance is improved. As a result, the organic light emitting diode including the second organic compound has advantages in the driving voltage, the emitting efficiency, the lifetime, the thermal stability and the color purity.

[0062] The second organic compound of the present invention may be one of the compounds in Formula 5.

[Formula 5]

PNH1

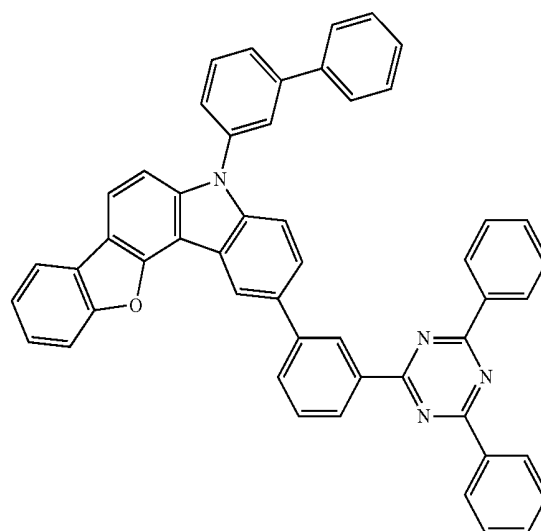

PNH2

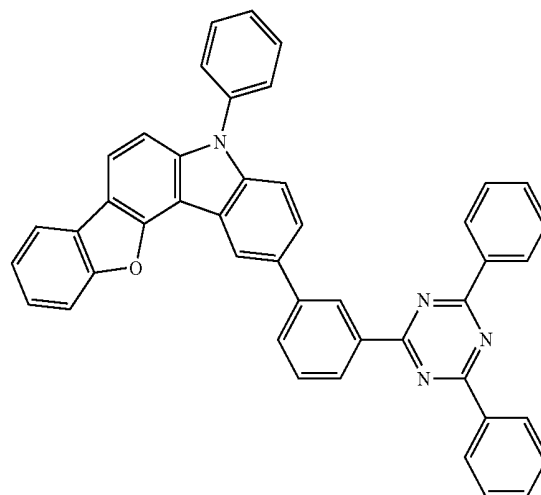

-continued

PNH3

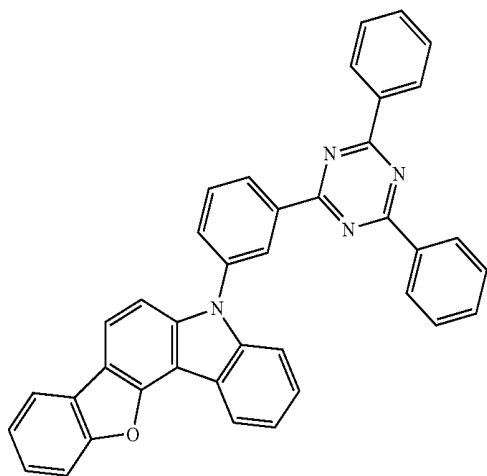

-continued

PNH6

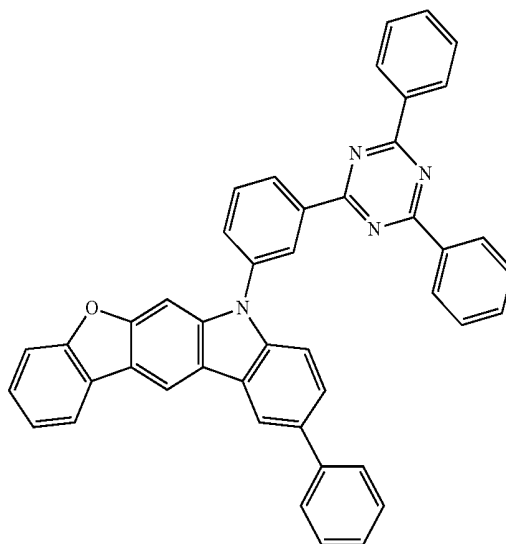

PNH4

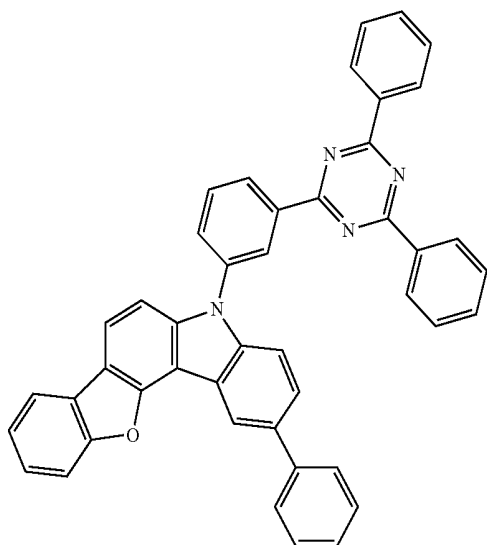

PNH7

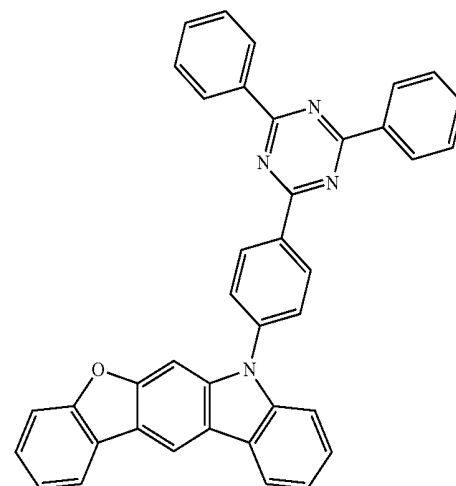

PNH5

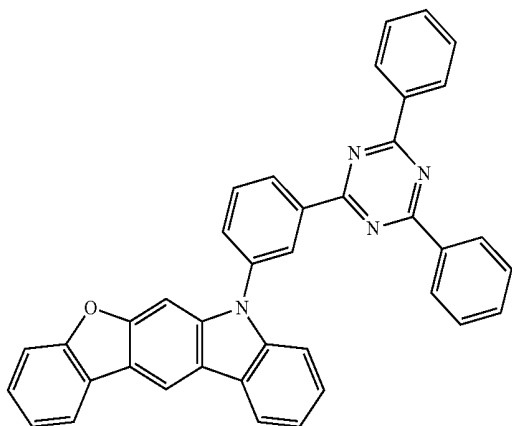

PNH8

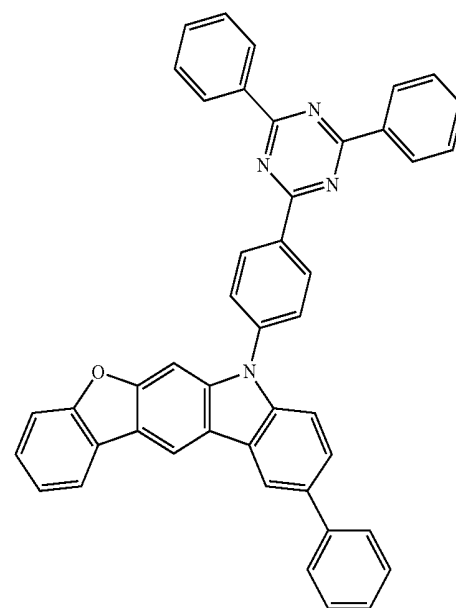

-continued

PNH9

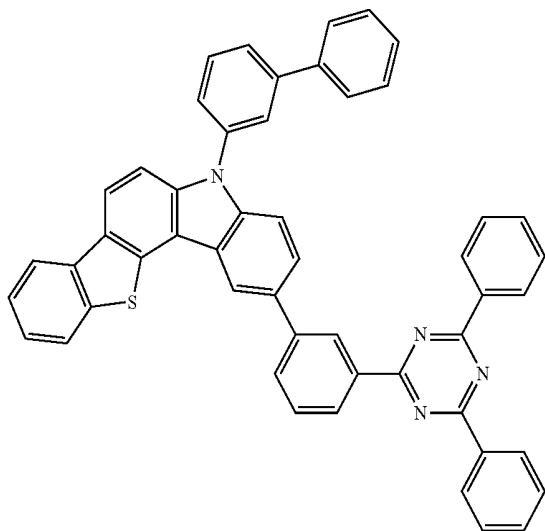

-continued

PNH12

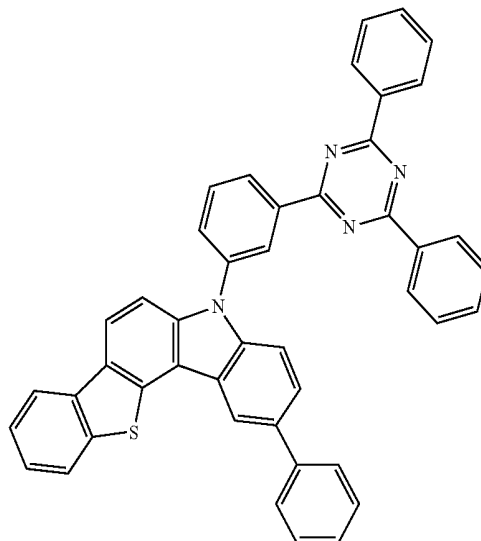

PNH10

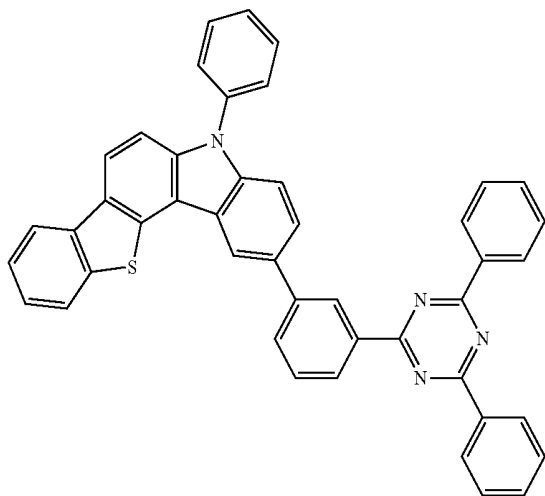

PNH13

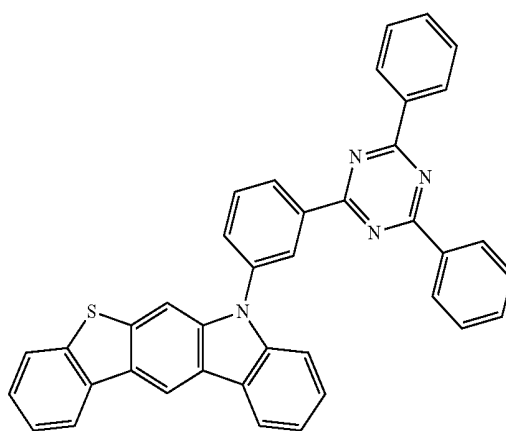

PNH11

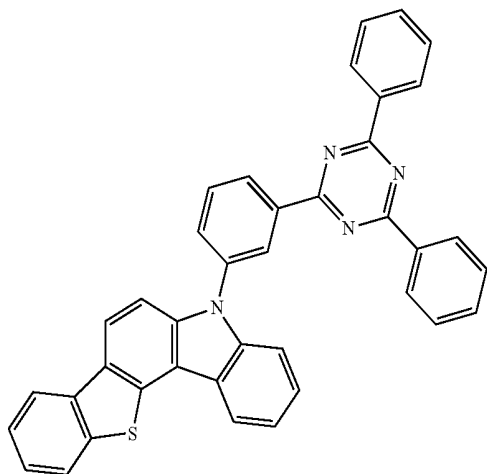

PNH14

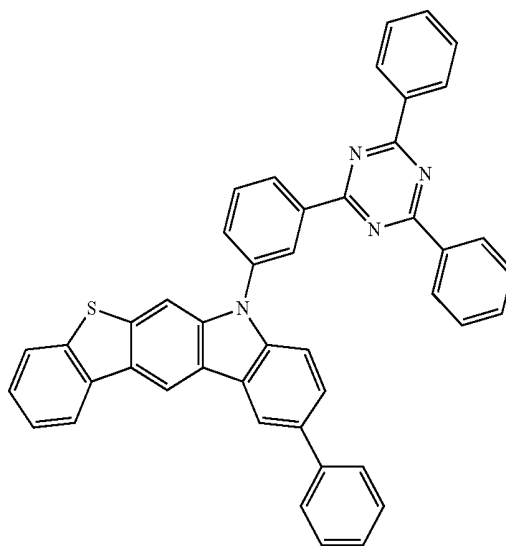

-continued

PNH15

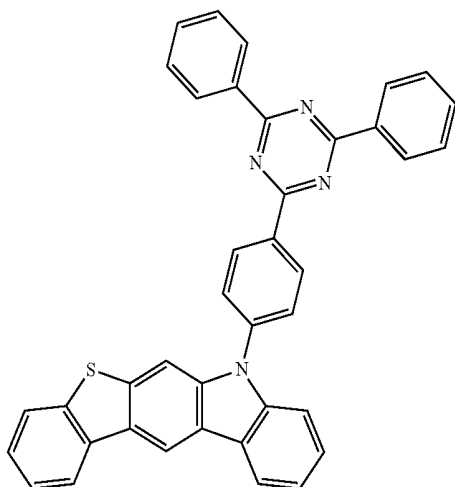

PNH16

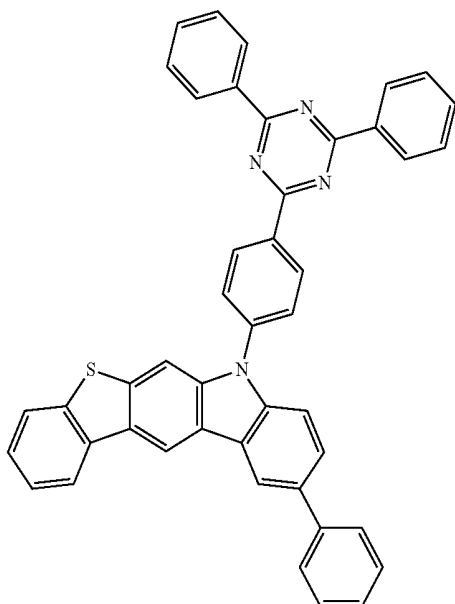

[0063] The second organic compound in Formulas 4a, 4b or 5 includes the fused carbazole moiety and the hetero aromatic moiety, which includes at least one atom having rich electron property and is directly or indirectly connected to the fused carbazole moiety, such that the second organic compound has excellent hole injection/transporting property and excellent electron injection/transporting property. The second organic compound in Formulas 4a or 4b may include at least one triazine moiety

[0064] The LUMO of the second organic compound is smaller (lower) than that of the dopant, and the second organic compound has a wide energy band gap, i.e., a gap (difference) between the LUMO and the HOMO. In addition, the second organic compound has the triplet energy being greater than the dopant. Accordingly, the second organic compound may be included in at least one of the EIL, the ETL and the HBL as well as at least one of the HIL, the HTL, the EBL and the EML.

[0065] Since the organic compound of the present invention has excellent properties in the thermal stability, the durability, the hole injection/transporting property and/or the

electron injection/transporting property, the organic compound is used in various organic layer of the organic light emitting diode.

[0066] FIG. 1 is a schematic cross-sectional view of an organic light emitting diode according to a first embodiment of the present invention.

[0067] As shown in FIG. 1, the organic light emitting diode 100 includes a first electrode 110, a second electrode 120 facing the first electrode 110, an emitting part 130 between the first and second electrodes 110 and 120. The emitting part 130 includes a hole auxiliary layer, which includes an HIL 140 and an HTL 150, an EML 160 and an electron auxiliary layer, which includes an ETL 170 and EIL 180, sequentially stacked on the first electrode 110.

[0068] The first electrode 110 as an anode includes a high work function conductive material, e.g., indium-tin-oxide (ITO) or indium-zinc-oxide (IZO).

[0069] The second electrode 120 as a cathode includes a low work function conductive material, e.g., aluminum (Al), magnesium (Mg), calcium (Ca), silver (Ag) or their alloy.

[0070] The HIL 140 is positioned between the first electrode 110 and the HTL 150. An interface property between the first electrode 110 of an inorganic material and the HTL 150 of an organic material is improved by the HIL 140. For example, the HIL 140 may include one of 4,4',4''-tris(3-methylphenylphenylamino)triphenylamine (MTDATA), copper phthalocyanine (CuPc), tris(4-carbazoyl-9-yl-phenyl)amine (TCTA), N,N'-diphenyl-N,N'-bis(1-naphthyl)-1,1'-biphenyl-4,4''-diamine (NPB or NPD), 1,4,5,8,9,11-hexaazatriphenylenehexacarbonitrile (HATCN), 1,3,5-tris[4-(diphenylamino)phenyl]benzene (TDAPB), poly(3,4-ethylenedioxythiophene)polystyrene sulfonate (PEDOT/PSS), 2,3,5,6-tetrafluoro-7,7,8,8-tetracyanoquinodimethane (F4TCNQ), N-(biphenyl-4-yl)-9,9-dimethyl-N-(4-(9-phenyl-9H-carbazol-3-yl)phenyl)-9H-fluoren-2-amine, a compound of following Formula 6.

[Formula 6]

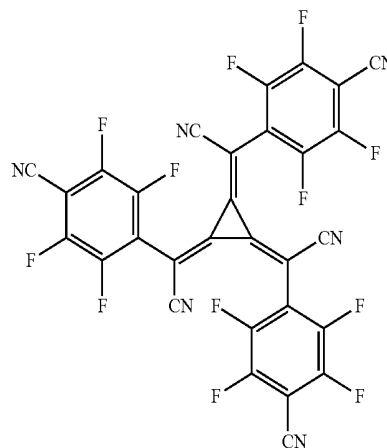

[0071] Alternatively, the HIL 140 may include the organic compound of the present invention in Formulas 1 to 5, e.g., the organic compound in above Formulas 2 and 3 or the organic compound in above Formulas 4a to 5.

[0072] The HTL 150 is positioned between the first electrode 110 and the EML 160 to be adjacent to the EML 160. Namely, the HTL 150 is positioned between the HIL 140 and

the EML **160**. For example, the HTL **150** may include aromatic amine compound such as N,N-diphenyl-N,N'-bis(3-methylphenyl)-1,1'-biphenyl-4,4'-diamine (TPD), NPD, 4,4'-bis(N-carbazolyl)-1,1'-biphenyl (CBP), N-(biphenyl-4-yl)-9,9-dimethyl-N-(4-(9-phenyl-9H-carbazol-3-yl)phenyl)-9H-fluoren-2-amine or N-(biphenyl-4-yl)-N-(4-(9-phenyl-9H-carbazol-3-yl)phenyl)biphenyl-4-amine.

[0073] Alternatively, the HTL **150** may include the organic compound of the present invention in Formulas 1 to 5, e.g., the organic compound in above Formulas 2 and 3 or the organic compound in above Formulas 4a to 5.

[0074] To improve the emitting efficiency of the organic light emitting diode **100**, the EML **160** may include a host and a dopant. The EML **160** may include the organic compound of the present invention in Formulas 1 to 5. For example, the first organic compound in Formulas 2 or 3 and/or the second organic compound in formulas 4a to 5 may be used as a host in the EML **160**.

[0075] Namely, one of the first organic compound and the second organic compound may be used in the EML **160**. Alternatively, both of the first and second organic compounds may be used in the EML **160**. It may be referred to as a two host system or a dual host system. When the first organic compound having excellent hole transporting property and the second organic compound having excellent hole and electron transporting property are used for the EML **150**, the charge transporting property is further improved.

[0076] In addition, in the two host system, the driving voltage of the organic light emitting diode **100** is lowered. Moreover, the emission is generated in entire region of the EML **160**, the emitting efficiency and the lifetime of the organic light emitting diode **100** are improved. Furthermore, by using the dopant having the triplet energy being smaller than the first and second organic compounds, the reverse-transition of the energy, which is transited from the host into the dopant, into the host is prevented such that the emitting efficiency is improved. Namely, the charge is efficiently transferred from the host into the dopant.

[0077] In the two host system, the first host may have a weight % of about 20 to 80 with respect to a total of the first and second host, beneficially 30 to 70, and more beneficially 40 to 60. By controlling the ratio of the first host to the second host, the charge balance in the EML **160** is also controlled or improved such that the emitting efficiency and the lifetime of the organic light emitting diode **100** are increased.

[0078] The EML **160** may further include a dopant. For example, the EML **160** may include a phosphorescent dopant. The phosphorescent dopant may be a metal complex, e.g., iridium (Ir), osmium (Os), copper (Cu) or platinum (Pt), but it is not limited thereto. The phosphorescent may be an Ir complex or a Pt complex, and preferably Ir complex. To efficiently transfer the charge from the host into the dopant and prevent the reverse-transition of the energy from the dopant into the host, the dopant may have an energy band gap between that of the first host (first organic compound) and that of the second host (second organic compound) and a triplet energy being smaller than that of each of the first and second hosts.

[0079] For example, the dopant in the EML **160** may be a material represented by Formulas 7 or 8, but it is not limited thereto.

[Formula 7]

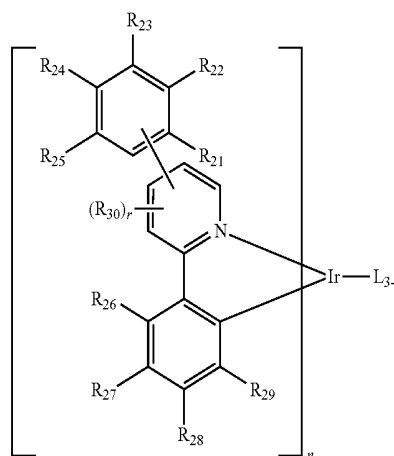

[Formula 8]

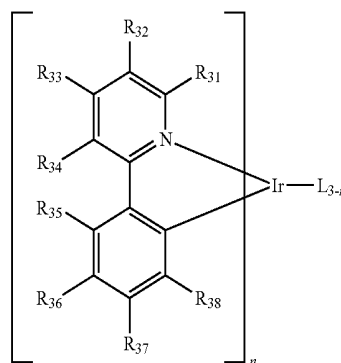

[0080] In Formula 7, each of R21 to R29 may be independently selected from the group consisting of hydrogen, deuterium, tritium, halogen, substituted or non-substituted C1 to C30 alkyl group, cyano group, substituted or non-substituted C3 to C30 cyclo-alkyl group, substituted or non-substituted C3 to C30 hetero cyclo-alkyl group, substituted or non-substituted C5 to C30 aryl group, substituted or non-substituted C5 to C30 heteroaryl group, substituted or non-substituted C6 to C30 arylalkyl group, substituted or non-substituted C6 to C30 hetero-arylalkyl group, substituted or non-substituted C6 to C30 aryloxy group and substituted or non-substituted C6 to C30 hetero-aryloxy group, R 30 may be selected from the group consisting of hydrogen, deuterium, tritium and substituted or non-substituted C 1 to C30 alkyl group, and "r" is an integer of 1 to 4.

[0081] In Formula 8, each of R31 to R38 may be independently selected from the group consisting of hydrogen, deuterium, tritium, halogen, substituted or non-substituted C1 to C30 alkyl group, cyano group, substituted or non-substituted C3 to C30 cyclo-alkyl group, substituted or non-substituted C3 to C30 hetero cyclo-alkyl group, substituted or non-substituted C5 to C30 aryl group, substituted or non-substituted C5 to C30 heteroaryl group, substituted or non-substituted C6 to C30 arylalkyl group, substituted or non-substituted C6 to C30 hetero-arylalkyl group, substituted or non-substituted C6 to C30 aryloxy group and substituted or non-substituted C6 to C30 hetero-aryloxy group, or adjacent two of R31 to R38 may form fused aromatic ring of C5 to C30. In Formulas 7 and 8, "n" is an integer of 1 to 3, and L is represented by Formula 9.

[Formula 9]

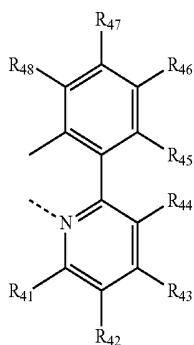

[0082] In Formula 9, each of R₄₁ to R₄₈ may be independently selected from the group consisting of hydrogen, deuterium, tritium, halogen, substituted or non-substituted C₁ to C₃₀ alkyl group, cyano group, substituted or non-substituted C₃ to C₃₀ cyclo-alkyl group, substituted or non-substituted C₃ to C₃₀ hetero cyclo-alkyl group, substituted or non-substituted C₅ to C₃₀ aryl group, substituted or non-substituted C₅ to C₃₀ heteroaryl group, substituted or non-substituted C₆ to C₃₀ arylalkyl group, substituted or non-substituted C₆ to C₃₀ hetero-arylalkyl group, substituted or non-substituted C₆ to C₃₀ aryloxy group and substituted or non-substituted C₆ to C₃₀ hetero-aryloxy group, or adjacent two of R₄₁ to R₄₈ may form a fused aromatic ring of C₅ to C₃₀.

[0083] The dopant in the EML **160** may be one of the compounds in Formula 10.

[Formula 10]

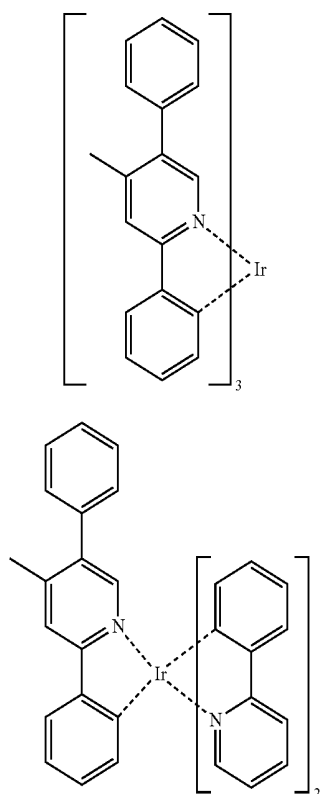

D1

D2

-continued

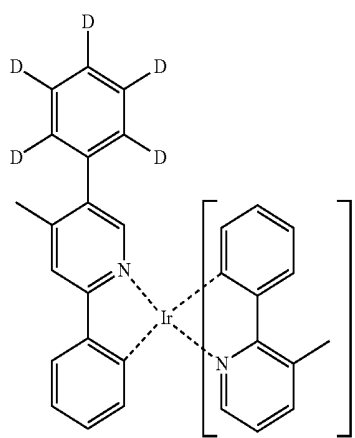

D3

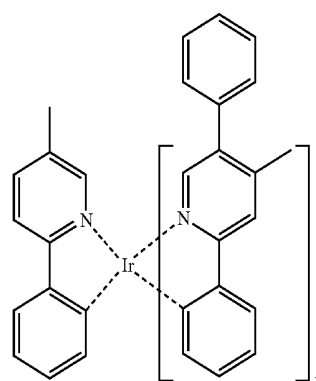

D4

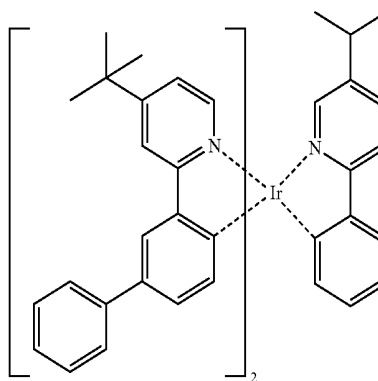

D5

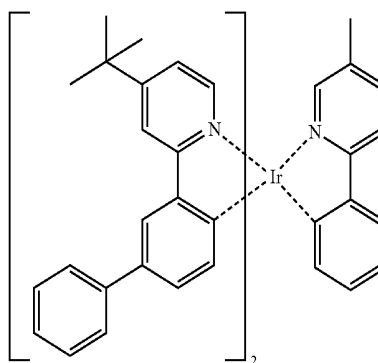

D6

-continued

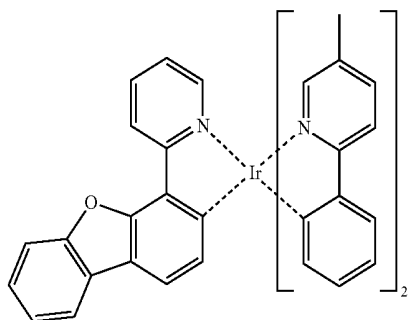

D7

-continued

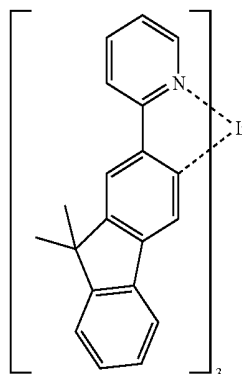

D11

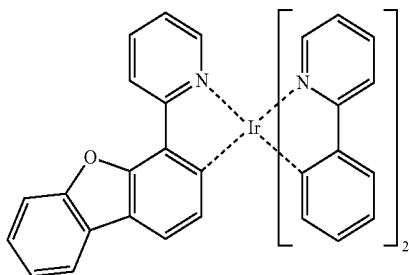

D8

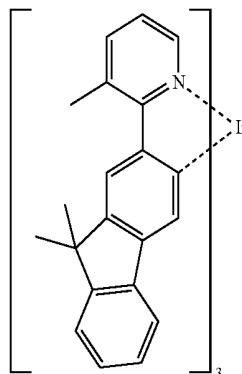

D12

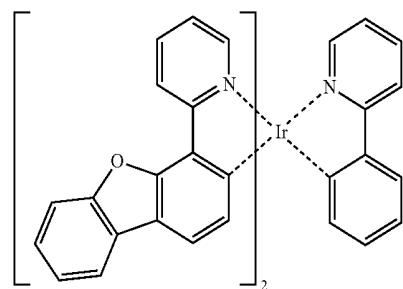

D9

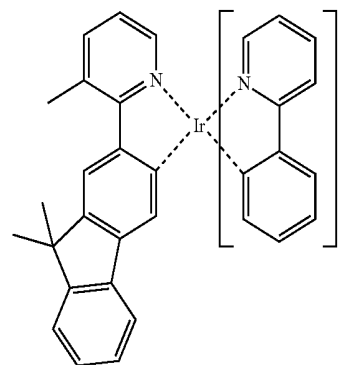

D13

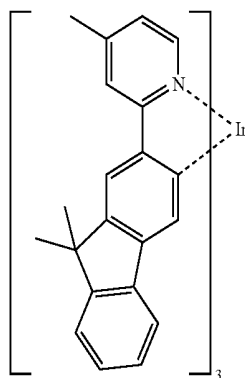

D10

[0084] The dopant may have a weight % of 0.1 to 50 with respect to a total of the first and second organic compounds in the EML **160**, and preferably about 1 to 20 weight %.

[0085] The ETL **170** and the EIL **180** may be sequentially stacked on the EML **160**. The ETL **170** includes a material having high electron mobility such that the electron is provided into the EML **160**.

[0086] For example, the ETL **170** may include one of tris-(8-hydroxyquinoline aluminum (Alq3), 2-biphenyl-4-yl-5-(4-t-butylphenyl)-1,3,4-oxadiazole (PBD), spiro-PBD, Liq, 2-[4-(9,10-Di-2-naphthalenyl-2-anthracenyl)phenyl]-1-phenyl-1H-benzimidazol, 3-(biphenyl-4-yl)-5-(4-tertbutylphenyl)-4-phenyl-4H-1,2,4-triazole (TAZ), 4,7-diphenyl-1,10-phenanthroline (Bphen), tris(phenylquinoxaline (TPQ), 1,3,5-tris(N-phenylbenzimidazole-2-yl)benzene (TPBI), or a material of Formula 11, but it is not limited thereto.

[Formula 11]

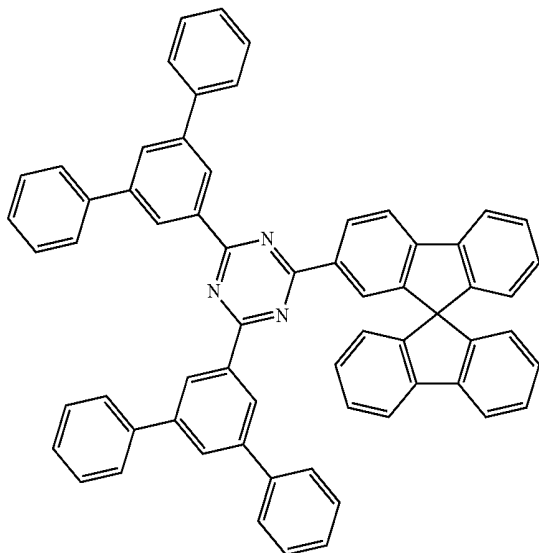

[0087] The ETL 170 may include the second organic compound in Formulas 4a to 5.

[0088] The EIL 180 is positioned between the ETL 170 and the second electrode 120, and the property of the second electrode 120 is enhanced by the EIL 180 such that the lifetime of the organic light emitting diode 100 is further improved. For example, the EIL 180 may include an alkali halide compound, e.g., LiF, CsF, NaF or BaF₂, or an organo-metallic compound, e.g., lithium quinolate (Liq), lithium benzoate or sodium stearate, but it is not limited thereto. The EIL 180 may include the second organic compound in Formulas 4a to 5.

[0089] When each of the ETL 170 and the EIL 180 include the organic compound of the present invention, i.e., the second organic compound, alkali metal or alkali earth metal as a dopant may be doped into ETL 170 and/or the EIL 180 such that the electron transporting and/or injection property is further improved. The alkali metal or the alkali earth metal may have a doping ration of about 1 to 20 weight % with respect to the second organic compound, but it is not limited thereto. For example, the dopant may be one of Li, Na, K, Cs, Mg, Sr, Ba and Ra, but it is not limited thereto.

[0090] The organic light emitting diode 100 includes the HIL 140, the HTL 150, the EML 160, the ETL 170 and the EIL 180 between the first and second electrodes 110 and 120, and the organic compound of the present invention may be used in at least one of the above layers with or without a dopant.

[0091] As mentioned above, since the organic compound of the invention includes the carbazole moiety, on which a side ring is fused, the thermal stability of the organic compound is increased. In the first organic compound, two fused carbazole moieties are connected to each other such that the first organic compound has excellent hole transporting property. On the other hand, in the second organic compound, a hetero aromatic ring, which includes a nitrogen atom, is directly or indirectly connected to a fused carbazole moiety such that the organic compound has excellent electron transporting property as well as excellent hole transporting property. Accordingly, when the organic compound

of the present invention is included in at least one organic layer of the organic light emitting diode 100, the charge is efficiently transferred such that the driving voltage of the organic light emitting diode 100 is reduced. For example, when the first and second organic compounds are included in the EML 160, the balance of the charges is improved such that the emission is generated in an entire region of the EML 160. As a result, the emission efficiency and the lifetime are improved.

[0092] FIG. 2 is a schematic cross-sectional view of an organic light emitting diode according to a second embodiment of the present invention.

[0093] As shown in FIG. 2, the organic light emitting diode 200 includes a first electrode 210, a second electrode 220 facing the first electrode 210, an emitting part 230 between the first and second electrodes 210 and 220. The emitting part 230 includes a hole auxiliary layer, which includes an HIL 240 and an HTL 250, an electron blocking layer (EBL) 310, an EML 260, a hole blocking layer (HBL) 320 and an electron auxiliary layer, which includes an ETL 270 and EIL 280, sequentially stacked on the first electrode 210.

[0094] The first electrode 210 as an anode includes a high work function conductive material, e.g., indium-tin-oxide (ITO) or indium-zinc-oxide (IZO).

[0095] The second electrode 220 as a cathode includes a low work function conductive material, e.g., aluminum (Al), magnesium (Mg), calcium (Ca), silver (Ag) or their alloy.

[0096] The HIL 240 is positioned between the first electrode 210 and the HTL 250. An interface property between the first electrode 210 of an inorganic material and the HTL 250 of an organic material is improved by the HIL 240. For example, the HIL 240 may include one of MTDATA, CuPc, TCTA, NPB, HATCN, TDAPB, PEDOT/PSS and the compound of above Formula 6.

[0097] Alternatively, the HIL 240 may include the organic compound of the present invention in Formulas 1 to 5, e.g., the organic compound in above Formulas 2 and 3 or the organic compound in above Formulas 4a to 5.

[0098] The HTL 250 is positioned between the first electrode 210 and the EML 260 to be adjacent to the EML 260. Namely, the HTL 250 is positioned between the HIL 240 and the EML 260. For example, the HTL 250 may include aromatic amine compound such as TPD, NPD, CBP, N-(biphenyl-4-yl)-9,9-dimethyl-N-(4-(9-phenyl-9H-carbazol-3-yl)phenyl)-9H-fluoren-2-amine or N-(biphenyl-4-yl)-N-(4-(9-phenyl-9H-carbazol-3-yl)phenyl)biphenyl-4-amine.

[0099] Alternatively, the HTL 250 may include the organic compound of the present invention in Formulas 1 to 5, e.g., the organic compound in above Formulas 2 and 3 or the organic compound in above Formulas 4a to 5.

[0100] When the hole is migrated toward the second electrode 220 or the electron is migrated toward the first electrode 210 beyond the EML 260, the lifetime and the emitting efficiency of the organic light emitting diode may be decreased. To prevent this problem, the organic light emitting diode of the present invention may include an exciton blocking layer at an upper side or a lower side of the EML 260.

[0101] For example, the EBL 310 is formed between the HTL 250 and the EML 260 to control or block the migration of the electron. The EML 310 may include one of 4,4',4''-Tris(carbazol-9-yl)-triphenylamine (TCTA) or N-(biphenyl-2-yl)-N-(9,9-dimethyl-9H-fluoren-2-yl)-9,9'-spiro[fluo-

ren]-2-amine. Alternatively, the EBL 310 may include the organic compound of the present invention in Formulas 1 to 3, e.g., the organic compound in above Formulas 2 and 3.

[0102] To improve the emitting efficiency of the organic light emitting diode 200, the EML 260 may include a host and a dopant. The EML 260 may include the organic compound of the present invention in Formulas 1 to 5. For example, the first organic compound in Formulas 2 or 3 and/or the second organic compound in formulas 4a to 5 may be used as a host in the EML 260.

[0103] The dopant in the EML 260 may be a phosphorescent dopant and may have a triplet energy being smaller than that of each of the first and second organic compounds. For example, the dopant in the EML 260 may be a material represented by above Formulas 7 to 9. In this instance, the dopant may have a weight % of 0.1 to 50 with respect to a total of the first and second organic compounds in the EML 260, and preferably about 1 to 20 weight %.

[0104] The HBL 320 is positioned between the EML 260 and the ETL 270 to block the migration of the hole between the EML 260 and the ETL 270. The HBL 320 may include a derivative compound of oxadiazole, triazole, phenanthroline, benzoxazole, benzothiazole, benzimidazole or triazine. For example, the HBL 320 may include a material having a relatively low highest occupied molecular orbital (HOMO), such as 2,9-dimethyl-4,7-diphenyl-1,10-phenanthroline (BCP), bis(2-methyl-8-quinolinolato)(4-phenylphenolato) aluminum (III) (BALq), Alq₃, 2-biphenyl-4-yl-5-(4-t-butylphenyl)-1,3,4-oxadiazole (PBD), spiro-PBD, lithium quinolate(Liq) or the material in above Formula 11, but it is not limited thereto.

[0105] Alternatively, the HBL 320 may include the second organic compound in above Formulas 4a to 5.

[0106] The ETL 270 and the EIL 280 may be sequentially stacked on the EML 260. The ETL 270 includes a material having high electron mobility such that the electron is provided into the EML 260.

[0107] For example, the ETL 270 may include a derivative compound of oxadiazole, triazole, phenanthroline, benzoxazole, benzothiazole, benzimidazole or triazine. For example, the HBL 320 may include BALq, Alq₃, PBD, spiro-PBD, Liq, 2-[4-(9,10-Di-2-naphthalenyl-2-anthracenyl)phenyl]-1-phenyl-1H-benzimidazol, TAZ, Bphen, TPQ, TPBI or the material in above Formula 11, but it is not limited thereto.

[0108] Alternatively, the ETL 270 may include the second organic compound in above Formulas 4a to 5.

[0109] The EIL 280 is positioned between the ETL 270 and the second electrode 220, and the property of the second electrode 220 is enhanced by the EIL 280 such that the lifetime of the organic light emitting diode 200 is further improved. For example, the EIL 280 may include an alkali halide compound, e.g., LiF, CsF, NaF or BaF₂, or an organo-metallic compound, e.g., lithium quinolate (Liq), lithium benzoate or sodium stearate, but it is not limited thereto. The EIL 280 may include the second organic compound in Formulas 4a to 5.

[0110] When each of the ETL 270 and the EIL 280 include the organic compound of the present invention, i.e., the second organic compound, alkali metal or alkali earth metal as a dopant may be doped into ETL 270 and/or the EIL 280 such that the electron transporting and/or injection property is further improved.

[0111] In comparison to the organic light emitting diode 100, the organic light emitting diode 200 further includes at least one of the EBL 310 under the EML 260 and the HBL 320 on the EML 260.

[0112] As mentioned above, since the organic compound of the invention includes the carbazole moiety, on which a side ring is fused, the thermal stability of the organic compound is increased. In the first organic compound, two fused carbazole moieties are connected to each other such that the first organic compound has excellent hole transporting property. On the other hand, in the second organic compound, a hetero aromatic ring, which includes a nitrogen atom, is directly or indirectly connected to a fused carbazole moiety such that the organic compound has excellent electron transporting property as well as excellent hole transporting property.

[0113] Accordingly, when the organic compound of the present invention is included in at least one organic layer of the organic light emitting diode 200, the charge is efficiently transferred such that the driving voltage of the organic light emitting diode 200 is reduced. For example, when the first and second organic compounds are included in the EML 260, the balance of the charges is improved such that the emission is generated in an entire region of the EML 260. As a result, the emission efficiency and the lifetime are improved. In addition, since the EBL 310 and the HBL 320 as the exciton blocking layer are included in the organic light emitting diode 200, the organic light emitting diode 200 is driven by low voltage and the emitting efficiency and the lifetime are improved.

[0114] FIG. 3 is a schematic cross-sectional view of an OLED device according to the present invention.

[0115] As shown in FIG. 3, the OLED device 400 includes a driving thin film transistor (TFT) Td, a planarization layer 460 covering the driving TFT Td, an organic light emitting diode E on the planarization layer 460 and connected to the driving TFT Td.

[0116] The driving TFT Td includes a semiconductor layer 440, a gate electrode 444, a source electrode 456 and a drain electrode 458. The driving TFT Td in FIG. 3 has a coplanar structure.

[0117] A substrate 401 may be a glass substrate or a plastic substrate and may serve as a base substrate. The semiconductor layer 440 is formed on the substrate 401. The semiconductor layer 440 may be formed of an oxide semiconductor material. When the semiconductor layer 440 includes the oxide semiconductor material, a light-shielding pattern (not shown) may be formed under the semiconductor layer 440. The light to the semiconductor layer 440 is shielded or blocked by the light-shielding pattern such that thermal degradation of the semiconductor layer 440 can be prevented. On the other hand, when the semiconductor layer 440 includes polycrystalline silicon, impurities may be doped into both sides of the semiconductor layer 440.

[0118] A gate insulating layer 442 is formed on the semiconductor layer 440 and over an entire surface of the substrate 401. The gate insulating layer 442 may be formed of an inorganic insulating material such as silicon oxide or silicon nitride.

[0119] The gate electrode 444, which is formed of a conductive material, e.g., metal, is formed on the gate insulating layer 442 to correspond to a center of the semiconductor layer 440. For example, the gate electrode 444 may be formed of a low resistance metal such as Al, Al alloy

(e.g., AlNd), W, Cu, Cu alloy, Mo, Ag, Ag alloy, Au, Au alloy, Cr, Ti, Ti alloy, MoW, MoTi or Cu—Mo—Ti.

[0120] In addition, a gate line (not shown) and a first capacitor electrode (not shown) may be formed on the gate insulating layer 442. The gate line may extend along a first direction, and the first capacitor electrode may be connected to the gate electrode 444. The gate insulating layer 442 in FIG. 3 covers an entire surface of the substrate 401. Alternatively, the gate insulating layer 442 may be patterned to have the same shape as the gate electrode 444.

[0121] An interlayer insulating layer 450, which is formed of an insulating material, is formed on an entire surface of the substrate 401 including the gate electrode 444. The interlayer insulating layer 450 may be formed of an inorganic insulating material, e.g., silicon oxide or silicon nitride, or an organic insulating material, e.g., benzocyclobutene or photo-acryl.

[0122] The interlayer insulating layer 450 includes first and second semiconductor contact holes 452 and 454 exposing both sides of the semiconductor layer 440. The first and second semiconductor contact holes 452 and 454 are positioned at both sides of the gate electrode 444 to be spaced apart from the gate electrode 444. In FIG. 3, the first and second semiconductor contact holes 452 and 454 are formed through the gate insulating layer 442 as well as the interlayer insulating layer 450. Alternatively, when the gate insulating layer 442 has the same shape as the gate electrode 444, the first and second semiconductor contact holes 452 and 454 may be formed in the interlayer insulating layer 450 except the gate insulating layer 442.

[0123] The source electrode 456 and the drain electrode 458, which are formed of a conductive material, e.g., metal, are formed on the interlayer insulating layer 450. The source and drain electrodes 456 and 458 may be formed of the same material as the gate electrode 444. In addition, a data line (not shown) extending along a second direction, a power line (not shown) and a second capacitor electrode (not shown) may be formed on the interlayer insulating layer 450. The data line crosses the gate line to define a pixel region, and the power line is spaced apart from and parallel to the data line. The second capacitor electrode is connected to the drain electrode 458 and overlaps the first capacitor electrode to form a storage capacitor with the interlayer insulating layer 450.

[0124] The source electrode 456 and the drain electrode 458 are spaced apart from each other with respect to the gate electrode 444 and respectively contact both sides of the semiconductor layer 440 through the first and second semiconductor contact holes 452 and 454.

[0125] In the driving TFT Td, the gate electrode 444, the source electrode 456 and the drain electrode 458 are positioned over the semiconductor layer 440. Namely, the driving TFT Td has a coplanar structure.

[0126] Alternatively, in the driving TFT Td, the gate electrode may be positioned under the semiconductor layer, and the source and drain electrodes may be positioned over the semiconductor layer such that the driving TFT Td may have an inverted staggered structure. In this instance, the semiconductor layer may include amorphous silicon.

[0127] A switching TFT (not shown) is formed on the substrate 401. The switching TFT may have substantially the same structure as the driving TFT Td. The gate electrode 444 is connected to a drain electrode of the switching TFT, and the source electrode 456 is connected to the power line. A

gate electrode and a source electrode of the switching TFT are connected to the gate line and the data line, respectively.

[0128] A planarization layer 460, which provides a flat top surface and includes a drain contact hole 462 exposing the drain electrode 458 of the driving TFT Td, is formed to cover the driving TFT Td. The drain contact hole 462 may be spaced apart from the second semiconductor contact hole 454 in a plane.

[0129] The organic light emitting diode E is disposed on the planarization layer 460 and includes a first electrode 410, an organic emitting layer 430 and a second electrode 420. The first electrode 410 is connected to the drain electrode 458 of the driving TFT Td, and the organic emitting layer 430 and the second electrode 420 are sequentially stacked on the first electrode 410. A bank 472 as a pixel definition layer is formed to cover an edge of the first electrode 410.

[0130] As mentioned above, the first electrode 410 as an anode includes a high work function conductive material, and the second electrode 420 as a cathode includes a low work function conductive material.

[0131] As explained above, the organic layer 430 includes at least one of the first and second organic compounds of the present invention with or without a dopant.

[0132] An encapsulation film 480 for preventing the penetration of moisture and/or oxygen into the organic light emitting diode E is formed on or over the second electrode 420. Although not shown, the encapsulation film 480 may have a triple-layered structure of a first inorganic layer, an organic layer and a second inorganic layer, which are sequentially stacked on or over the second electrode 420, but it is not limited thereto.

[0133] As mentioned above, since the organic compound of the invention includes the carbazole moiety, on which a side ring is fused, the thermal stability of the organic compound is increased. In the first organic compound, two fused carbazole moieties are connected to each other such that the first organic compound has excellent hole transporting property. On the other hand, in the second organic compound, a hetero aromatic ring, which includes a nitrogen atom, is directly or indirectly connected to a fused carbazole moiety such that the organic compound has excellent electron transporting property as well as excellent hole transporting property. Accordingly, when the organic compound of the present invention is included in at least one organic layer of the organic light emitting diode E, the charge is efficiently transferred such that the driving voltage of the OLED device 400 is reduced. For example, when the first and second organic compounds are included in the EML (160 in FIG. 1 or 260 in FIG. 2), the balance of the charges is improved such that the emission is generated in an entire region of the EML (160 in FIG. 1 or 260 in FIG. 2). As a result, the emission efficiency and the lifetime of the OLED device 400 are improved.

Synthesis

[0134] 1. Synthesis of the Compound PPH1

(1) 2,4-dibromo-1-nitrobenzene

[0135] [Reaction Formula 1a]

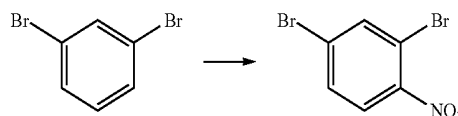

[0136] Sulfuric acid (744 mL) and nitric acid (144 mL) were mixed. In the temperature of 0° C., 1,3-dibromobenzene (300 g, 1,270 mmol) were slowly dropped and stirred for 30 minutes. After completion of the reaction, ice water was slowly dropped into the mixture, and the solid was filtered and extracted using ethylacetate in several times. The organic solvent was removed, and the silica-gel column process was performed to obtain 2,4-dibromo-1-nitrobenzene (261 g, yield: 73%).

(2) 4-(5-bromo-2-nitrophenyl)dibenzo[b,d]furan

[0137] [Reaction Formula 1b]

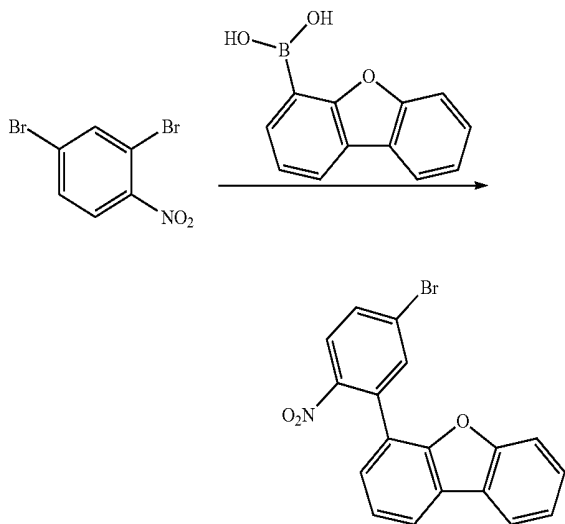

[0138] 2,4-dibromo-1-nitrobenzene (100 g, 356 mmol), dibenzofuran boronic acid 75 g (356 mmol), Pd(pph3)₄ 12.3 g (10.6 mmol) and K₂CO₃ 98.4 g (712 mmol) were dissolved in a mixture of ethyl alcohol (336 mL), distilled water (336 mL) and toluene (1680 mL) and stirred for 2 hours. After completion of the reaction, the mixture was distilled under the reduced pressure. The silica-gel column process was performed to obtain 4-(5-bromo-2-nitrophenyl)dibenzo[b,d]furan (60 g, yield: 45%).

(3) 2-bromo-5H-benzofuro[3,2-c]carbazole

[0139] [Reaction Formula 1c]

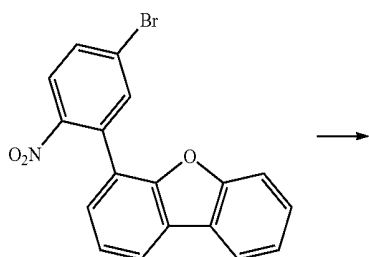

-continued

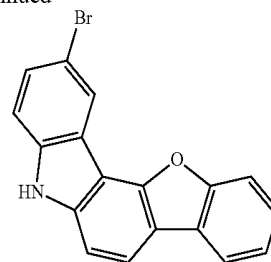

[0140] 4-(5-bromo-2-nitrophenyl)dibenzo[b,d]furan (140 g, 380 mmol) and triphenylphosphine (299 g, 1,149 mmol) were dissolved in 1,2-dichlorobenzene (980 mL) and stirred for 12 hours. The solvent was removed by concentration under the reduced pressure, and the silica-gel column process was performed to obtain 2-bromo-5H-benzofuro[3,2-c]carbazole (25 g, yield: 20%).

(4) 2-(9-phenyl-9H-carbazol-3-yl)-5H-benzofuro[3,2-c]carbazole

[0141] [Reaction Formula 1d]

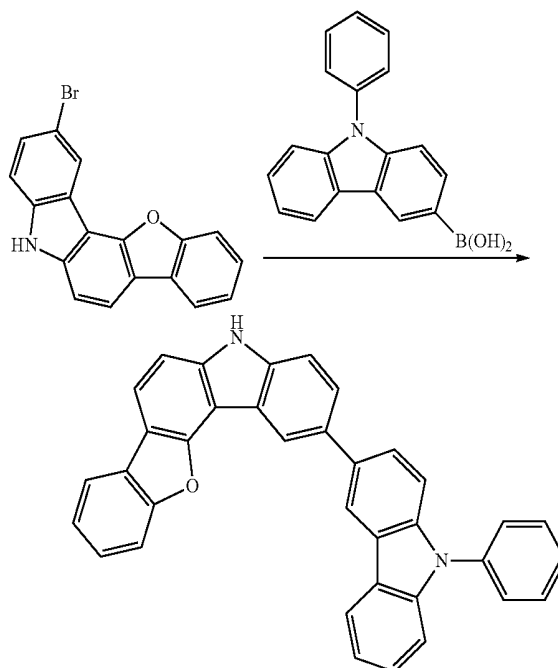

[0142] 2-bromo-5H-benzofuro[3,2-c]carbazole (6.5 g, 19 mmol), 9-phenyl-9H-carbazol-3-yl-boronic acid (6.6 g, 23 mmol), Pd(pph3)C14 (0.9 g, 0.8 mmol) and K₂CO₃ (7.1 g, 51 mmol) were dissolved in a mixture of ethyl alcohol (33 mL), distilled water (26 mL) and toluene (65 mL). The mixture was refluxed and stirred for 12 hours. The resultant was cooled into the room temperature, and the extracted solid was filtered. The solid was washed using methyl alcohol in several times to obtain 2-(9-phenyl-9H-carbazol-3-yl)-5H-benzofuro[3,2-c]carbazole (7 g, yield: 74%).

(5) 2,2'-dibromobiphenyl

[0143] [Reaction Formula 1e]

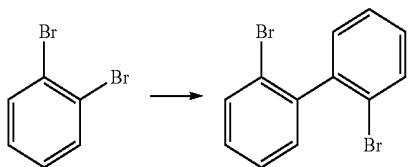

[0144] 1,2-Dibromobenzene (51 mL, 424 mmol) was dissolved in THF and cooled into the temperature of -78°C . n-BuLi (90 mL, 2.5M, 225 mmol) was slowly dropped into the solution for 1 hour and stirred under the room temperature for 12 hours. The mixture was quenched by water and extracted by ether. After the solvent was removed, the resultant was re-precipitated using hexane such that 2,2'-dibromobiphenyl was obtained. (29.4 g, yield: 22%)

(6) 9-(2'-bromobiphenyl-2-yl)-9H-fluoren-9-ol

[0145] [Reaction Formula 1f]

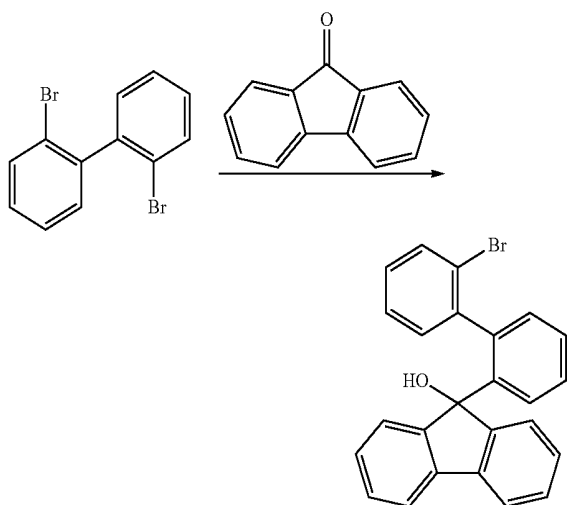

[0146] 2,2'-dibromobiphenyl (29.4 g, 94.2 mmol) was dissolved in THF and cooled into the temperature of -78°C . n-BuLi (37 mL, 2.5M, 94 mmol) was slowly dropped into the solution, and fluorene (20.4 g, 113 mmol), which is dissolved in THF, was slowly dropped. The solution was slowly heated up to the room temperature and stirred for 12 hours. The mixture was quenched by distilled water and extracted by ether such that the yellow solid (9-(2'-bromobiphenyl-2-yl)-9H-fluoren-9-ol) was obtained. (36 g)

(7) 4-bromo-9,9'-spirobi[fluorene]

[0147] [Reaction Formula 1g]

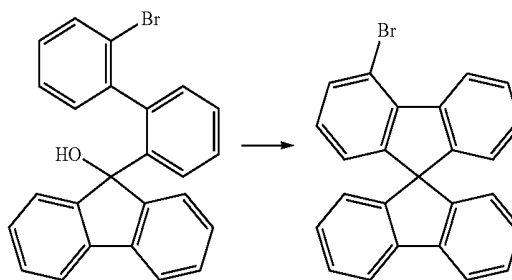

[0148] 9-(2'-bromobiphenyl-2-yl)-9H-fluoren-9-ol (36 g, 94 mmol) was dissolved in a mixture of acetic acid (360 mL) and hydrochloric acid (36 mL, 36%). The mixture was refluxed and stirred for 12 hours. After removing the solvent, the silica-gel column was performed such that 4-bromo-9,9'-spirobi[fluorene] was obtained. (32 g, yield: 86%)

(8) the compound PPH1

[0149] [Reaction Formula 1h]

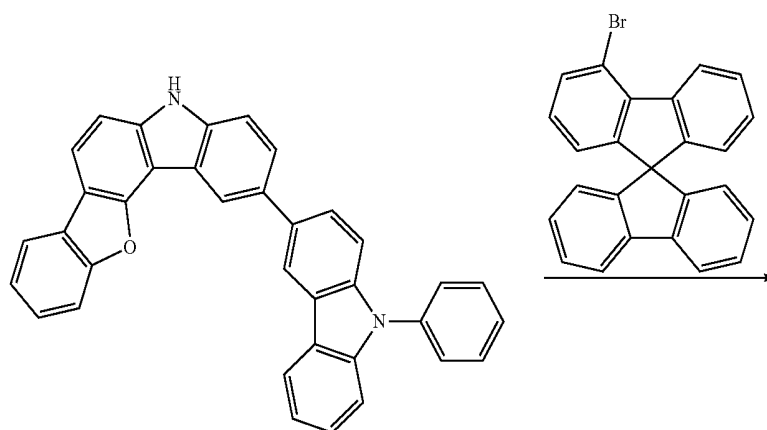

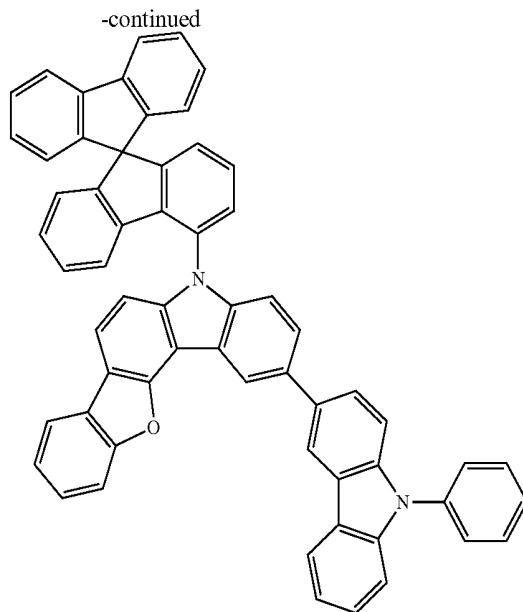

[0150] 2-(9-phenyl-9H-carbazol-3-yl)-5H-benzofuro[3,2-c]carbazole (7 g, 14 mmol), 4-bromo-9,9'-spirobifluorene (6.7 g, 17 mmol), Pd2(dba)3 (0.64 g, 0.7 mmol), tert-tributylphosphine (0.17 g, 0.84 mmol) and tert-sodiumbutoxide (3.56 g, 37 mmol) were dissolved in toluene (280 mL). The mixture was refluxed and stirred for 48 hours, and the resultant was extracted 3 times by methylenechloride. The resultant was concentrated under the reduced pressure, washed and columned in the silica-gel such that the compound PPH1 was obtained. (2.5 g, yield: 22%)

[0151] 2. Synthesis of the Compound PPH3

(1) 9-(biphenyl-3-yl)-9H-carbazole

[0152] [Reaction Formula 2a]

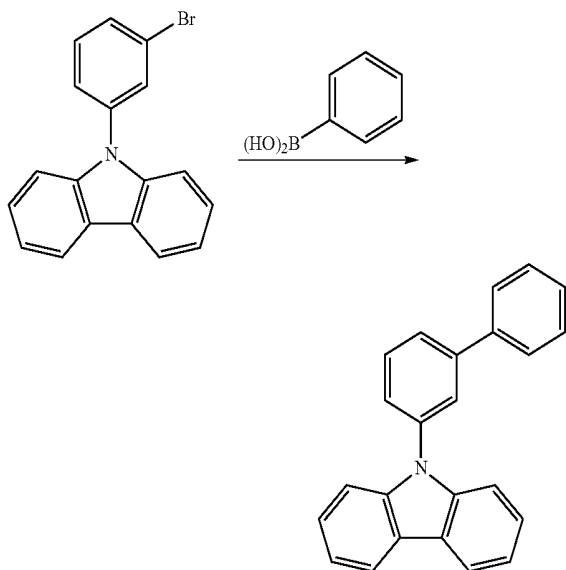

[0153] 3-bromo-phenylcarbazole (20 g, 62 mmol), phenyl boronic acid (9.08 g, 74 mmol), Pd(pph3)C14 (0.7 g, 0.621

mmol) and K2CO3 (17.2 g, 124 mmol) were dissolved in a mixture of ethyl alcohol (200 mL) and toluene (800 mL). The mixture was refluxed and stirred for 12 hours. The resultant was re-precipitated to obtain 9-(biphenyl-3-yl)-9H-carbazole (16.2 g, yield: 82%).

(2) 9-(biphenyl-3-yl)-3-bromo-9H-carbazole

[0154] [Reaction Formula 2b]

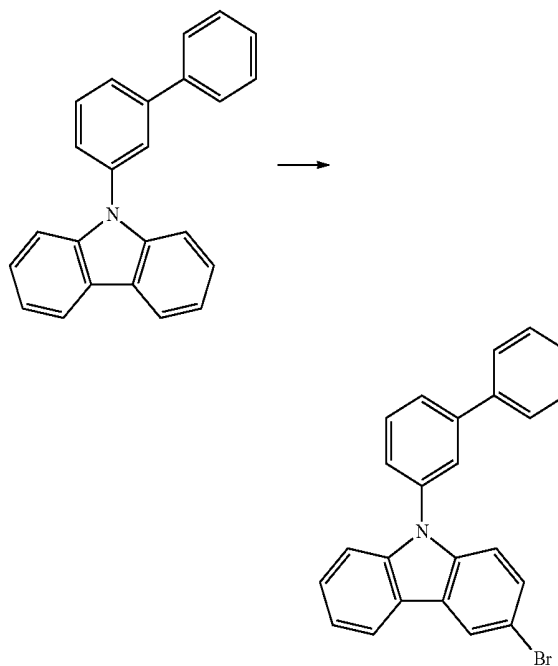

[0155] 9-(biphenyl-3-yl)-9H-carbazole (16.2 g, 50.7 mmol) was dissolved in chloroform (320 mL), and NBS (9.03 g, 50.7 mmol) was slowly dropped. The mixture was refluxed and stirred for 5 hours. After completion of the reaction, distilled water was added and extracted. The resul-

tant was columned in the silica-gel such that crude-state 9-(biphenyl-3-yl)-3-bromo-9H-carbazole (17.2 g) was obtained.

(3) 9-(biphenyl-3-yl)-9H-carbazol-3-ylboronic acid

[0156] [Reaction Formula 2c]

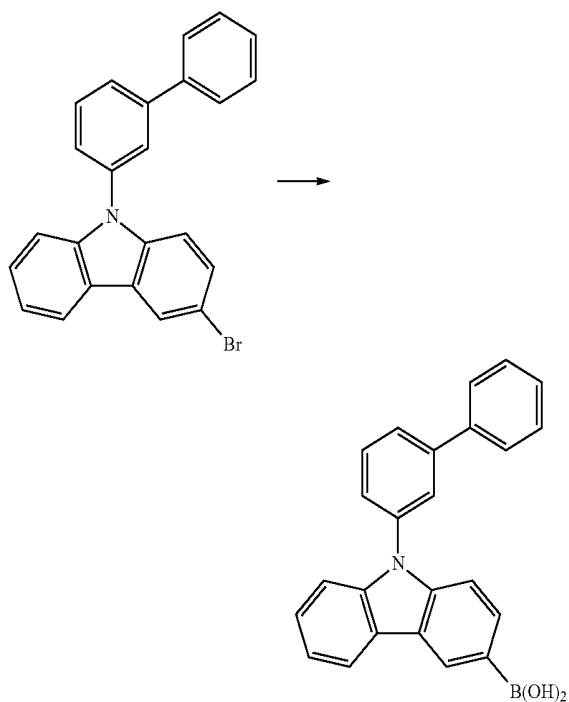

[0157] 9-(biphenyl-3-yl)-3-bromo-9H-carbazole (17.2 g, 43.1 mmol) was dissolved in THF (172 mL) and cooled into the temperature of -78°C . n-BuLi (20.7 mL, 2.5M, 51.7 mmol) was slowly dropped into the solution and stirred for 1 hour. Triethylborate (8.8 mL, 51.7 mmol) was added, and the solution was stirred under the room temperature for 12 hours. After completion of the reaction, the resultant was re-precipitated using TFH and hexane such that 9-(biphenyl-3-yl)-9H-carbazol-3-ylboronic acid (12 g, yield: 76%) was obtained.

(4) 2-(9-(biphenyl-3-yl)-9H-carbazol-3-yl)-5H-benzofuro[3,2-c]carbazole

[0158] [Reaction Formula 2d]

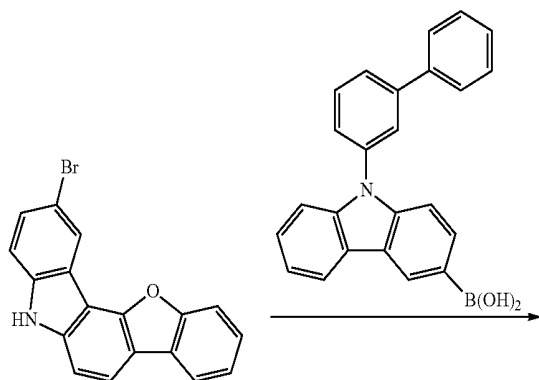

-continued

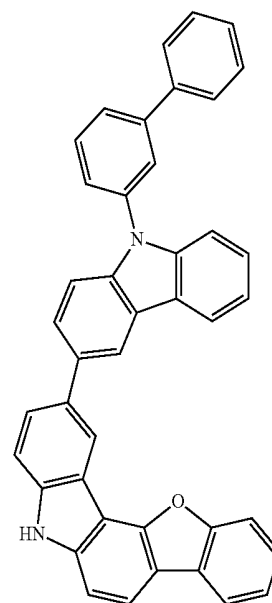

[0159] 2-bromo-5H-benzofuro[3,2-c]carbazole (5.4 g, 16.06 mmol), 9-(biphenyl-3-yl)-9H-carbazol-3-ylboronic acid (7 g, 19.27 mmol), Pd(pph3)4 (0.9 g, 0.8 mmol) and K2CO3 (6.66 g, 48 mmol) were dissolved in a mixture of ethyl alcohol (30 mL), distilled water (30 mL) and toluene (50 mL). The mixture was refluxed and stirred for 12 hours. After extracting by ethylacetate, the resultant was columned in the silica-gel such that 2-(9-(biphenyl-3-yl)-9H-carbazol-3-yl)-5H-benzofuro[3,2-c]carbazole (4.5 g, yield: 49%) was obtained.

(5) The Compound PPH3

[0160] [Reaction Formula 2e]

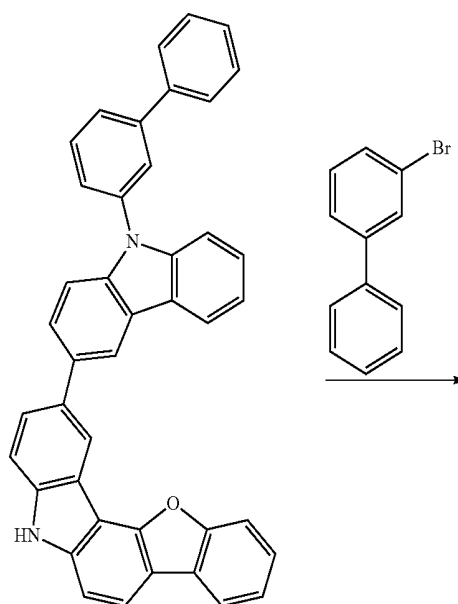

-continued

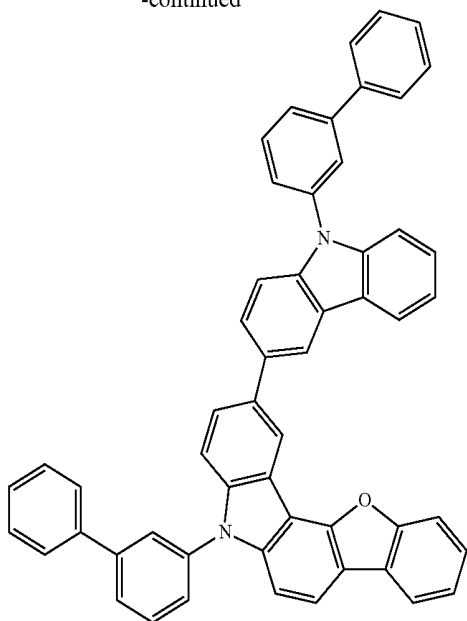

[0161] 2-(9-(biphenyl-3-yl)-9H-carbazol-3-yl)-5H-benzofuro[3,2-c]carbazole (4.5 g, 7.83 mmol), 3-bromobiphenyl (5.48 g, 23.5 mmol), Pd₂(dba)₃ (0.28 g), tert-butylphosphine (0.95 mg, 0.470 mmol) and tert-sodiumbutoxide (1.66 g, 17.2 mmol) were dissolved in toluene (100 mL). The mixture was refluxed and stirred for 12 hours. The resultant was columned in the silica-gel such that the compound PPH3 was obtained. (2 g, yield: 56%)

[0162] 3. Synthesis of the Compound PPH5

(1) 3-(biphenyl-3-yl)-3H-benzofuro[2,3-b]carbazole

[0163] [Reaction Formula 3a]

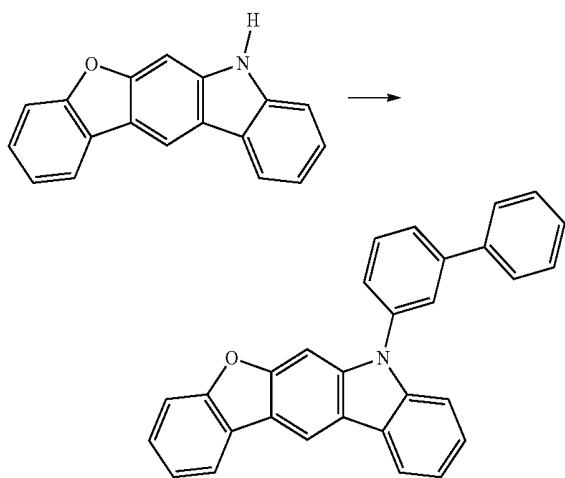

[0164] Dibenzofurocarbazole (77 g, 299 mmol), 3-metabromobiphenyl (60 g, 359 mmol), sodium-tert-butoxide (86 g, 897 mmol), Pd₂(dba)₃ (14 g, 359 mmol) and tri-tert-butylphosphine (15 mL, 30 mmol) were suspended in xylene (1000 mL). The solution was refluxed and stirred for 12 hours. The resultant was extracted by dichloromethane and distilled water, and the organic layer was filled in the

silica-gel. After removing the organic solvent, the resultant was columned in the silica-gel such that 3-(biphenyl-3-yl)-3H-benzofuro[2,3-b]carbazole (80 g, yield: 65%) was obtained.

(2) 3-(biphenyl-3-yl)-6-bromo-3H-benzofuro[2,3-b]carbazole

[0165] [Reaction Formula 3b]

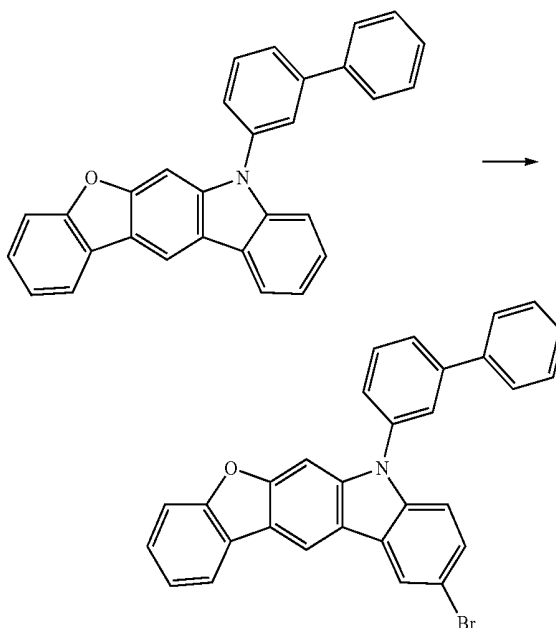

[0166] 3-(biphenyl-3-yl)-3H-benzofuro[2,3-b]carbazole (47 g, 114 mmol) and NBS (22 g, 126 mmol) were suspended in dimethylformamide (600 mL) and stirred under the room temperature for 12 hours. After distilled water was added, the mixture was stirred under the room temperature for 6 hours. After filtering under the reduced pressure, the solid was added in methyl alcohol and stirred under the room temperature. The resultant was filtered under the reduced pressure such that 3-(biphenyl-3-yl)-6-bromo-3H-benzofuro[2,3-b]carbazole (50 g, yield: 71%) was obtained.

(3) 3-(biphenyl-3-yl)-6-(4,4,5,5-tetramethyl-1,3,2-dioxaborolan-2-yl)-3H-benzofuro[2,3-b]carbazole

[0167] [Reaction Formula 3c]

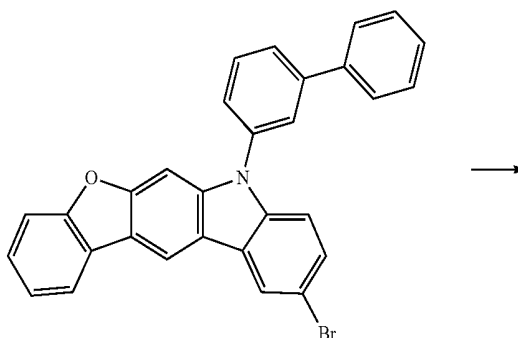

-continued

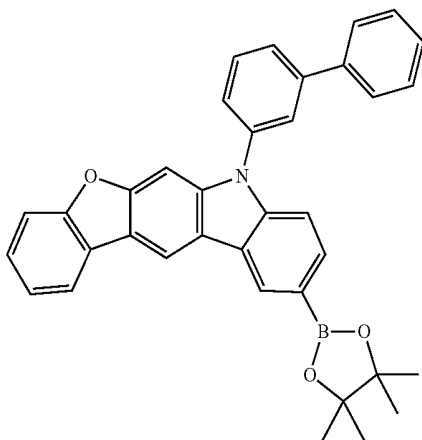

[0168] 3-(biphenyl-3-yl)-6-bromo-3H-benzofuro[2,3-b]carbazole (49 g, 100 mmol), bis(pinacolato)diboron (38 g, 151 mmol), Pd(dppf)Cl₂ (4 g, 5 mmol) and potassium acetate (20 g, 201 mmol) were suspended in 1,4-dioxane (600 mL) and refluxed/stirred for 12 hours. The mixture was extracted by dichloromethane and distilled water, and the organic layer is filled in the silica-gel. After removing the organic solvent, the solid was re-crystallized such that 3-(biphenyl-3-yl)-6-(4,4,5,5-tetramethyl-1,3,2-dioxaborolan-2-yl)-3H-benzofuro[2,3-b]carbazole (40 g, yield: 75%) was obtained.

[0169] (4) the Compound PPH5

[0170] [Reaction Formula 3d]

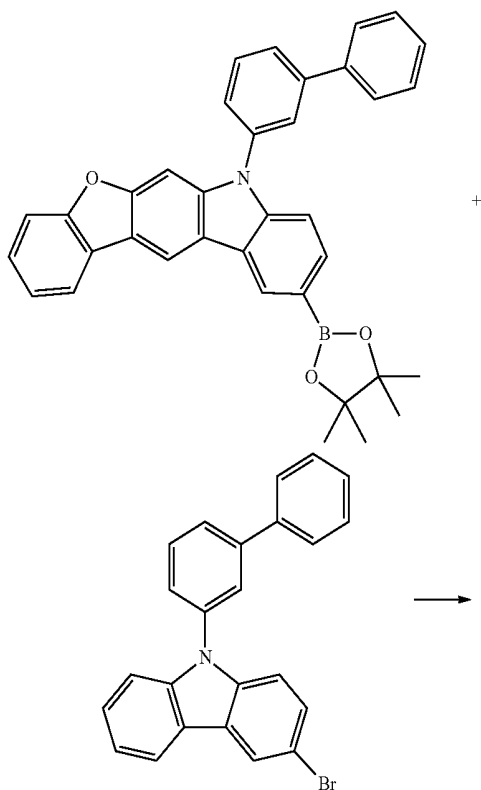

-continued

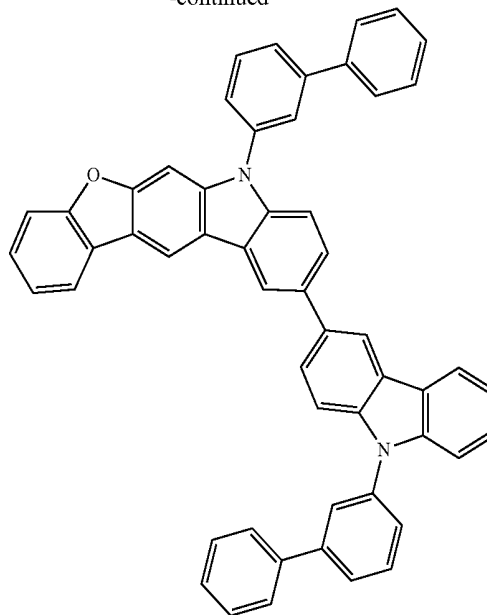

[0171] 3-(biphenyl-3-yl)-6-(4,4,5,5-tetramethyl-1,3,2-dioxaborolan-2-yl)-3H-benzofuro[2,3-b]carbazole (10 g, 19 mmol), 9-meta-biphenyl-3-bromocarbazole (7 g, 19 mmol), Pd(PPh₃)₄ (0.2 g, 0.2 mmol) and potassium carbonate (5 g, 37 mmol) were suspended in a mixture of toluene (150 mL), ethylalcohol (50 mL) and distilled water (50 mL) and refluxed/stirred for 12 hours. The mixture was extracted by dichloromethane and distilled water, and the organic layer is filled in the silica-gel. After the resultant was distilled under the reduced pressure, the solid was re-crystallized such that the compound PPH5 (8 g, yield: 59%) was obtained.

[0172] 4. Synthesis of the Compound PPH7

(1) 3-(biphenyl-3-yl)-3H-benzofuro[2,3-b]carbazole

[0173] [Reaction Formula 4a]

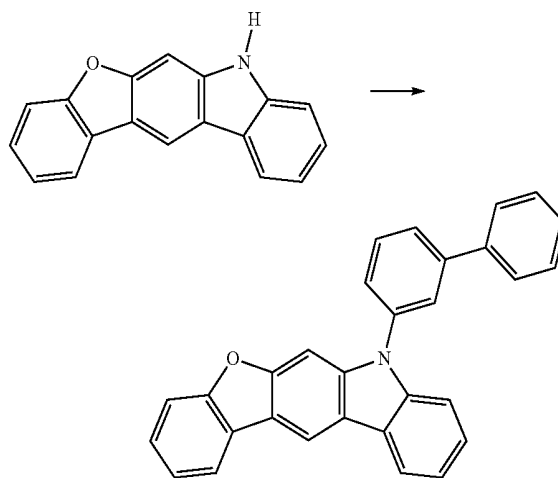

[0174] Dibenzofurocarbazole (77 g, 299 mmol), 3-meta-bromobiphenyl (60 g, 359 mmol), sodium-tert-butoxide (86 g, 897 mmol), Pd₂(dba)₃ (14 g, 359 mmol) and tri-tert-butylphosphine (15 mL, 30 mmol) were suspended in xylene

(1000 mL). The solution was refluxed and stirred for 12 hours. The resultant was extracted by dichloromethane and distilled water, and the organic layer was filled in the silica-gel. After removing the organic solvent, the resultant was columned in the silica-gel such that 3-(biphenyl-3-yl)-3H-benzofuro[2,3-b]carbazole (80 g, yield: 65%) was obtained.

(2) 3-(biphenyl-3-yl)-6-bromo-3H-benzofuro[2,3-b]carbazole

[0175] [Reaction Formula 4b]

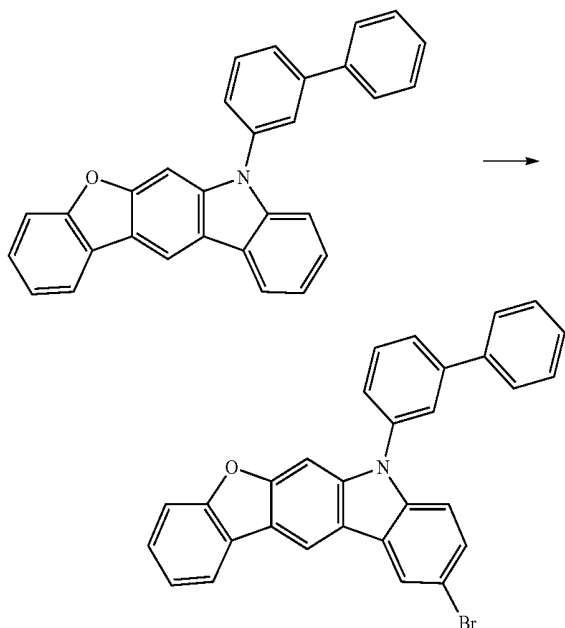

[0176] 3-(biphenyl-3-yl)-3H-benzofuro[2,3-b]carbazole (47 g, 114 mmol) and NBS (22 g, 126 mmol) were suspended in dimethylformamide (600 mL) and stirred under the room temperature for 12 hours. After distilled water was added, the mixture was stirred under the room temperature for 6 hours. After filtering under the reduced pressure, the solid was added in methyl alcohol and stirred under the room temperature. The resultant was filtered under the reduced pressure such that 3-(biphenyl-3-yl)-6-bromo-3H-benzofuro[2,3-b]carbazole (50 g, yield: 71%) was obtained.

(3) 3-(biphenyl-3-yl)-6-(4,4,5,5-tetramethyl-1,3,2-dioxaborolan-2-yl)-3H-benzofuro[2,3-b]carbazole

[0177] [Reaction Formula 4c]

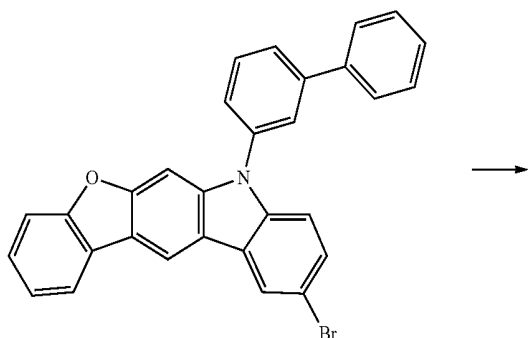

-continued

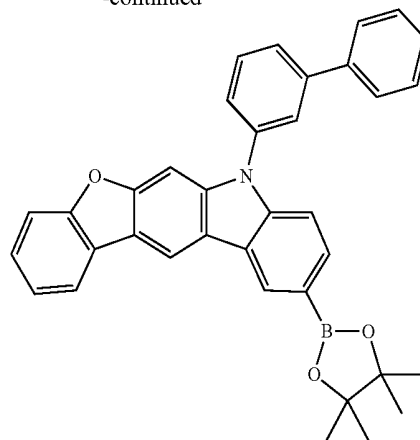

[0178] 3-(biphenyl-3-yl)-6-bromo-3H-benzofuro[2,3-b]carbazole (49 g, 100 mmol), bis(pinacolato)diboron (38 g, 151 mmol), Pd(dppf)Cl₂ (4 g, 5 mmol) and potassium acetate (20 g, 201 mmol) were suspended in 1,4-dioxane (600 mL) and refluxed/stirred for 12 hours. The mixture was extracted by dichloromethane and distilled water, and the organic layer is filled in the silica-gel. After removing the organic solvent, the solid was re-crystallized such that 3-(biphenyl-3-yl)-6-(4,4,5,5-tetramethyl-1,3,2-dioxaborolan-2-yl)-3H-benzofuro[2,3-b]carbazole (40 g, yield: 75%) was obtained.

[0179] (4) the Compound PPH7

[0180] [Reaction Formula 4d]

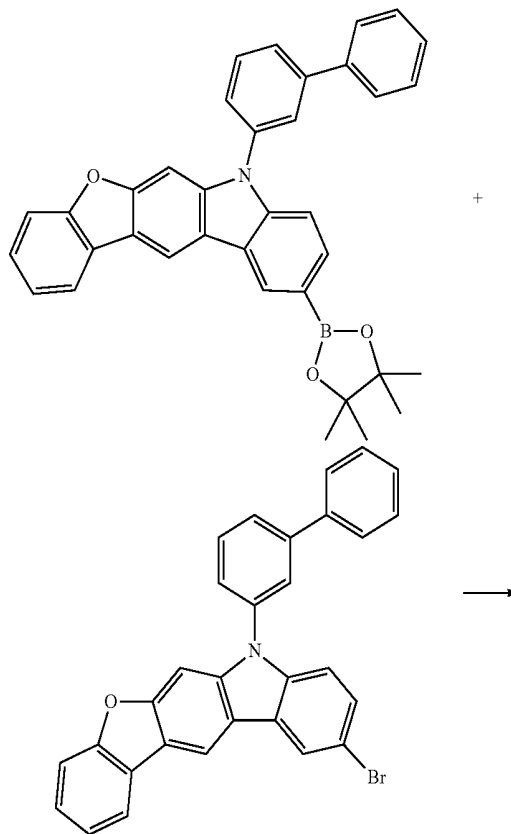

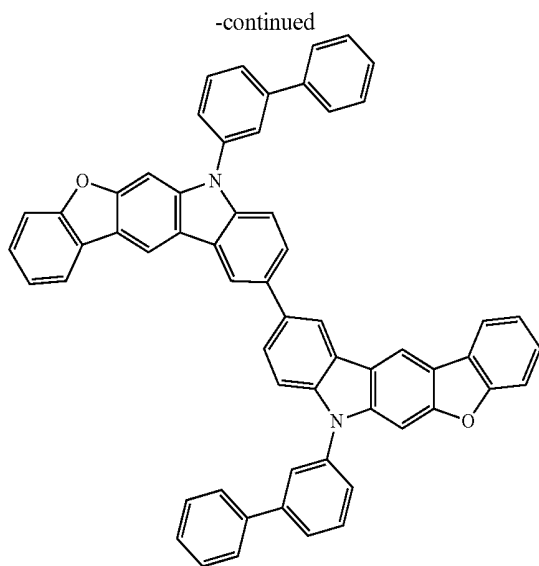

[0181] 3-(biphenyl-3-yl)-6-(4,4,5,5-tetramethyl-1,3,2-dioxaborolan-2-yl)-3H-benzofuro [2,3-b]carbazole (10 g, 19 mmol), 3-(biphenyl-3-yl)-6-bromo-3H-benzofuro[2,3-b]carbazole (9 g, 19 mmol), Pd(PPh₃)₄ (0.2 g, 0.2 mmol) and potassium carbonate (5 g, 37 mmol) were suspended in a mixture of toluene (150 mL), ethylalcohol (50 mL) and distilled water (50 mL) and refluxed/stirred for 12 hours. The mixture was extracted by dichloromethane and distilled water, and the organic layer is filled in the silica-gel. After the resultant was distilled under the reduced pressure, the solid was re-crystallized such that the compound PPH7 (8 g, yield: 59%) was obtained.

[0182] 5. Synthesis of the Compound PPH9

(1) Benzothieno Carbazole Derivative

[0183] [Reaction Formula 5a]

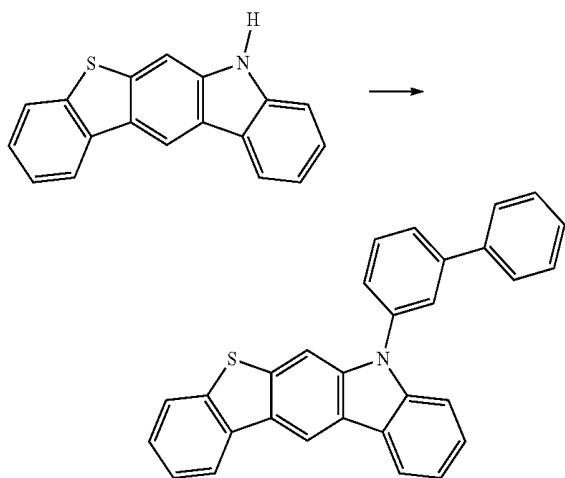

[0184] Benzothieno carbazole (77 g, 302 mmol), 3-meta-bromobiphenyl (60 g, 359 mmol), sodium-tert-butoxide (86 g, 897 mmol), Pd₂(dba)₃ (14 g, 359 mmol) and tri-tert-butylphosphine (15 mL, 30 mmol) were suspended in xylene (1000 mL). The solution was refluxed and stirred for 12 hours. The resultant was extracted by dichloromethane and

distilled water, and the organic layer was filled in the silica-gel. After removing the organic solvent, the resultant was columned in the silica-gel such that benzothieno carbazole derivative (80 g, yield: 65%) was obtained.

(2) Bromo-Benzothieno Carbazole Derivative

[0185] [Reaction Formula 5b]

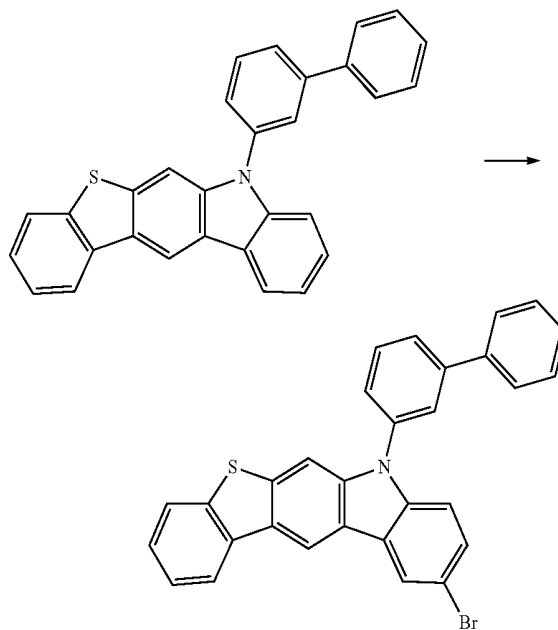

[0186] Benzothieno carbazole derivative (47 g, 120 mmol) and NBS (22 g, 126 mmol) were suspended in dimethylformamide (600 mL) and stirred under the room temperature for 12 hours. After distilled water was added, the mixture was stirred under the room temperature for 6 hours. After filtering under the reduced pressure, the solid was added in methyl alcohol and stirred under the room temperature. The resultant was filtered under the reduced pressure such that bromo-benzothieno carbazole derivative (50 g, yield: 71%) was obtained.

(3) Pinacol-Benzothieno Carbazole Derivative

[0187] [Reaction Formula 5c]

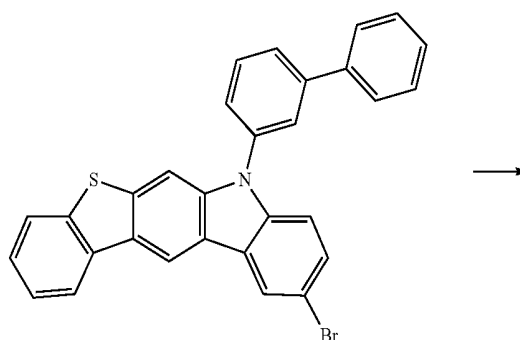

-continued

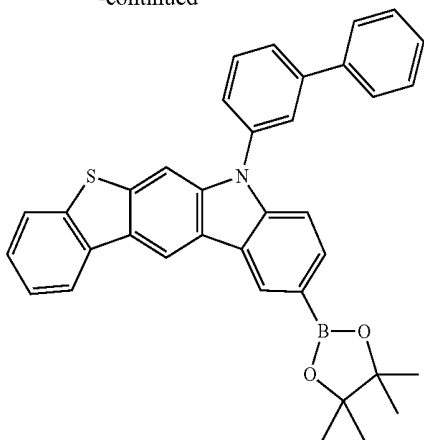

[0188] Bromo-benzothieno carbazole derivative (49 g, 105 mmol), bis(pinacolato)diboron (38 g, 151 mmol), Pd(dppf)Cl₂ (4 g, 5 mmol) and potassium acetate (20 g, 201 mmol) were suspended in 1,4-dioxane (600 mL) and refluxed/stirred for 12 hours. The mixture was extracted by dichloromethane and distilled water, and the organic layer is filled in the silica-gel. After removing the organic solvent, the solid was re-crystallized such that pinacol-benzothieno carbazole derivative (40 g, yield: 75%) was obtained.

(4) The Compound PPH9

[0189] [Reaction Formula 5d]

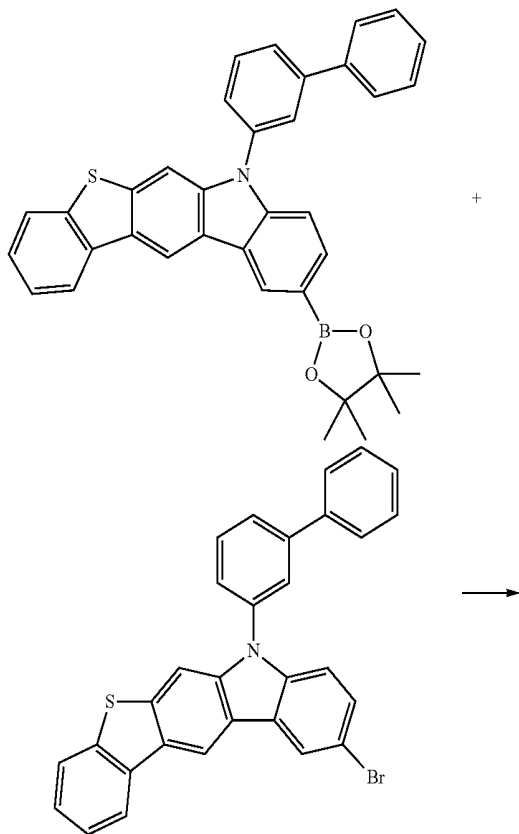

-continued

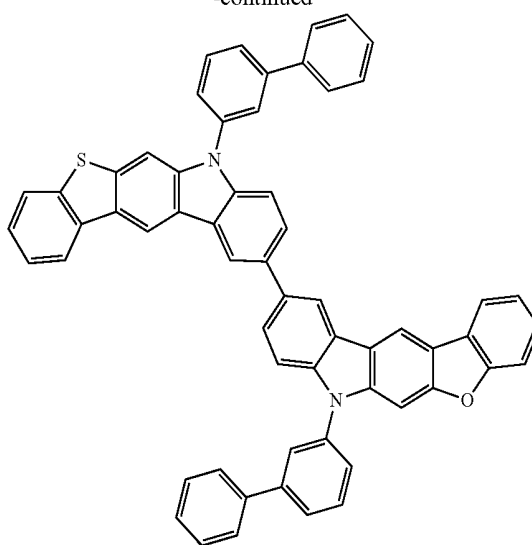

[0190] Pinacol-benzothieno carbazole derivative (10 g, 19 mmol), bromo-benzothieno carbazole derivative (9 g, 19 mmol), Pd(PPh₃)₄ (0.2 g, 0.2 mmol) and potassium carbonate (5 g, 37 mmol) were suspended in a mixture of toluene (150 mL), ethylalcohol (50 mL) and distilled water (50 mL) and refluxed/stirred for 12 hours. The mixture was extracted by dichloromethane and distilled water, and the organic layer is filled in the silica-gel. After the resultant was distilled under the reduced pressure, the solid was re-crystallized such that the compound PPH9 (7 g, yield: 49%) was obtained.

[0191] 6. Synthesis of the compound PPH11

(1) 6-bromo-1,1-dimethyl-3-phenyl-1,3-dihydroindeno[2,1-b]carbazole

[0192] [Reaction Formula 6a]

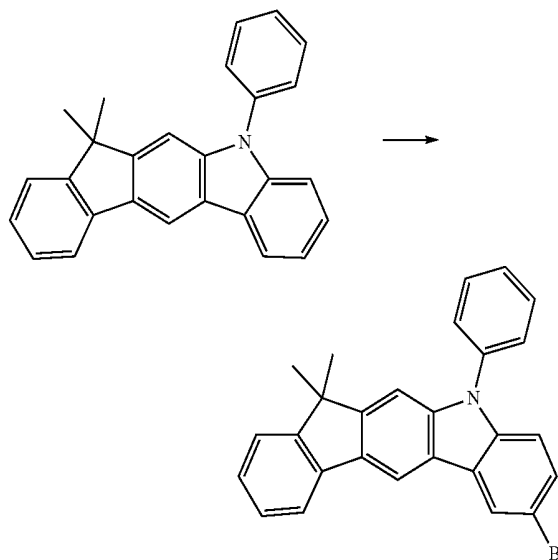

[0193] 5-phenyl-indenocarbazole (43 g, 120 mmol), and NBS (22 g, 126 mmol) were suspended in dimethylformamide (600 mL) and stirred under the room temperature for 12 hours. After distilled water was added, the mixture was stirred under the room temperature for 6 hours. After filtering under the reduced pressure, the solid was added in methyl alcohol and stirred under the room temperature. The resultant was filtered under the reduced pressure such that 6-bromo-1,1-dimethyl-3-phenyl-1,3-dihydroindeno[2,1-b] carbazole (45 g, yield: 86%) was obtained.

(2) 1,1-dimethyl-3-phenyl-6-(4,4,5,5-tetramethyl-1,3,2-dioxaborolan-2-yl)-1,3-dihydroindeno[2,1-b] carbazole

[0194] [Reaction Formula 6b]

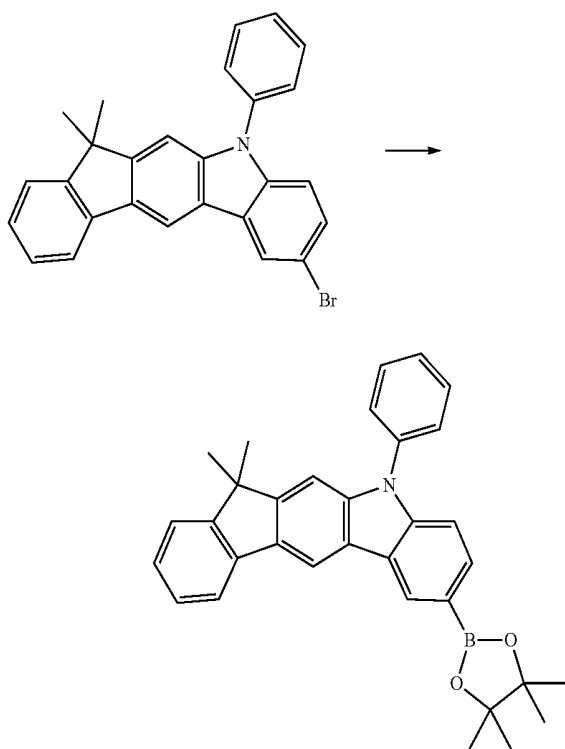

[0195] 6-bromo-1,1-dimethyl-3-phenyl-1,3-dihydroindeno[2,1-b]carbazole (46 g, 105 mmol), bis(pinacolato) diboron (38 g, 156 mmol), Pd(dppf)Cl₂ (4 g, 5 mmol) and potassium acetate (20 g, 201 mmol) were suspended in 1,4-dioxane (600 mL) and refluxed/stirred for 12 hours. The mixture was extracted by dichloromethane and distilled water, and the organic layer is filled in the silica-gel. After removing the organic solvent, the solid was re-crystallized such that 1,1-dimethyl-3-phenyl-6-(4,4,5,5-tetramethyl-1,3,2-dioxaborolan-2-yl)-1,3-dihydroindeno[2,1-b] carbazole (40 g, yield: 78%) was obtained.

(3) The Compound PPH11

[0196] [Reaction Formula 6c]

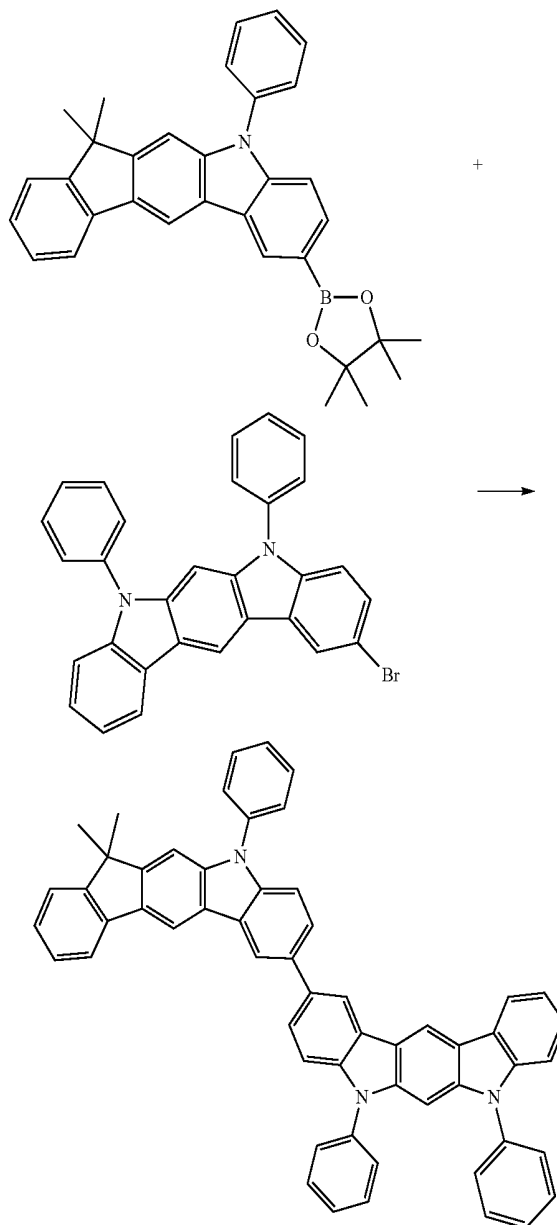

[0197] 1,1-dimethyl-3-phenyl-6-(4,4,5,5-tetramethyl-1,3,2-dioxaborolan-2-yl)-1,3-dihydroindeno[2,1-b]carbazole (10 g, 19 mmol), 3-bromo-9,9-phenyl-indolo-carbazole (10 g, 20 mmol), Pd(PPh₃)₄ (0.2 g, 0.2 mmol) and potassium carbonate (5 g, 40 mmol) were suspended in a mixture of toluene (150 mL), ethylalcohol (50 mL) and distilled water (50 mL) and refluxed/stirred for 12 hours. The mixture was extracted by dichloromethane and distilled water, and the organic layer is filled in the silica-gel. After the resultant was distilled under the reduced pressure, the solid was re-crystallized such that the compound PPH11 (10 g, yield: 63%) was obtained.

[0198] 7. Synthesis of the Compound PPH13

(1) 3'-phenyl-3'H-spiro[fluorene-9,1'-indeno[2,1-b]carbazole]

[0199] [Reaction Formula 7a]

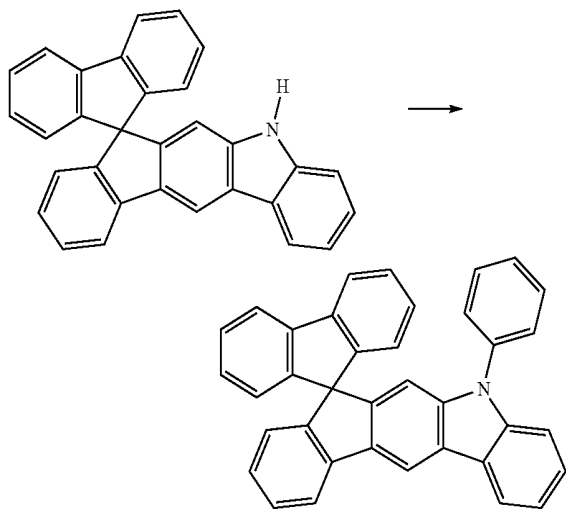

[0200] Spiro-bifluorene-indenocarbazole (121 g, 299 mmol), iodobenzene (73 g, 359 mmol), sodium-tert-butoxide (86 g, 897 mmol), Pd₂(dba)₃ (14 g, 359 mmol) and tri-tert-butylphosphine (15 mL, 30 mmol) were suspended in xylene (1000 mL). The solution was refluxed and stirred for 12 hours. The resultant was extracted by dichloromethane and distilled water, and the organic layer was filled in the silica-gel. After removing the organic solvent, the resultant was columned in the silica-gel such that 3'-phenyl-3'H-spiro[fluorene-9,1'-indeno[2,1-b]carbazole] (100 g, yield: 69%) was obtained.

(2) 6'-bromo-3'-phenyl-3'H-spiro[fluorene-9,1'-indeno[2,1-b]carbazole]

[0201] [Reaction Formula 7b]

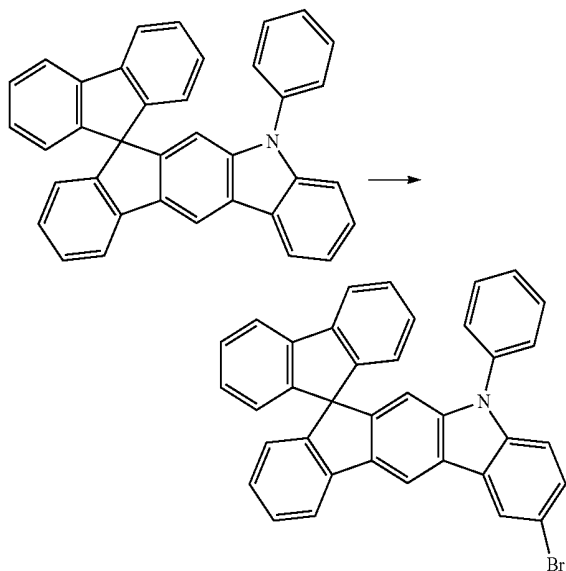

[0202] 3'-phenyl-3'H-spiro[fluorene-9,1'-indeno[2,1-b]carbazole] (55 g, 114 mmol) and NBS (22 g, 126 mmol) were suspended in dimethylformamide (600 mL) and stirred under the room temperature for 12 hours. After distilled water was added, the mixture was stirred under the room temperature for 6 hours. After filtering under the reduced pressure, the solid was added in methyl alcohol and stirred under the room temperature. The resultant was filtered under the reduced pressure such that 6'-bromo-3'-phenyl-3'H-spiro[fluorene-9,1'-indeno[2,1-b]carbazole] (50 g, yield: 78%) was obtained.

(3) 3'-phenyl-6'-(4,4,5,5-tetramethyl-1,3,2-dioxaborolan-2-yl)-3'H-spiro[fluorene-9,1'-indeno[2,1-b]carbazole]

[0203] [Reaction Formula 7c]

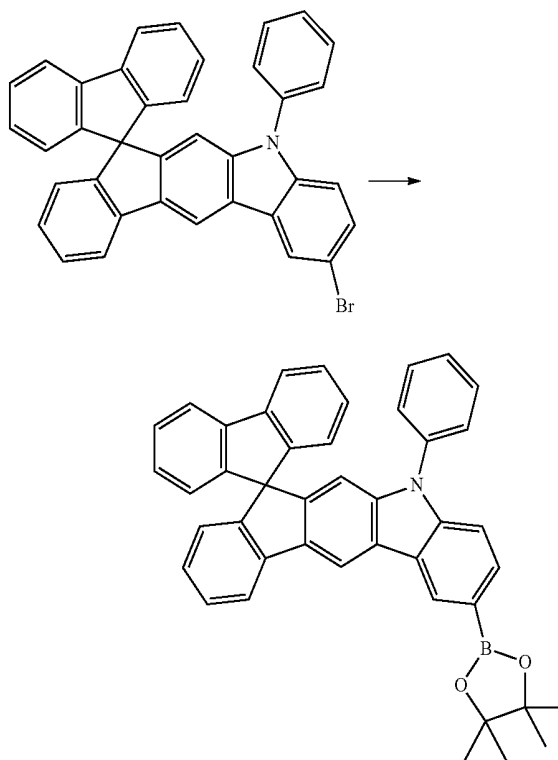

[0204] 6'-bromo-3'-phenyl-3'H-spiro[fluorene-9,1'-indeno[2,1-b]carbazole] (56 g, 100 mmol), bis(pinacolato)diboron (38 g, 151 mmol), Pd(dppf)Cl₂ (4 g, 5 mmol) and potassium acetate (20 g, 201 mmol) were suspended in 1,4-dioxane (600 mL) and refluxed/stirred for 12 hours. The mixture was extracted by dichloromethane and distilled water, and the organic layer is filled in the silica-gel. After removing the organic solvent, the solid was re-crystallized such that 3'-phenyl-6'-(4,4,5,5-tetramethyl-1,3,2-dioxaborolan-2-yl)-3'H-spiro[fluorene-9,1'-indeno[2,1-b]carbazole] (45 g, yield: 74%) was obtained.

(4) The Compound PPH13

[0205] [Reaction Formula 7d]

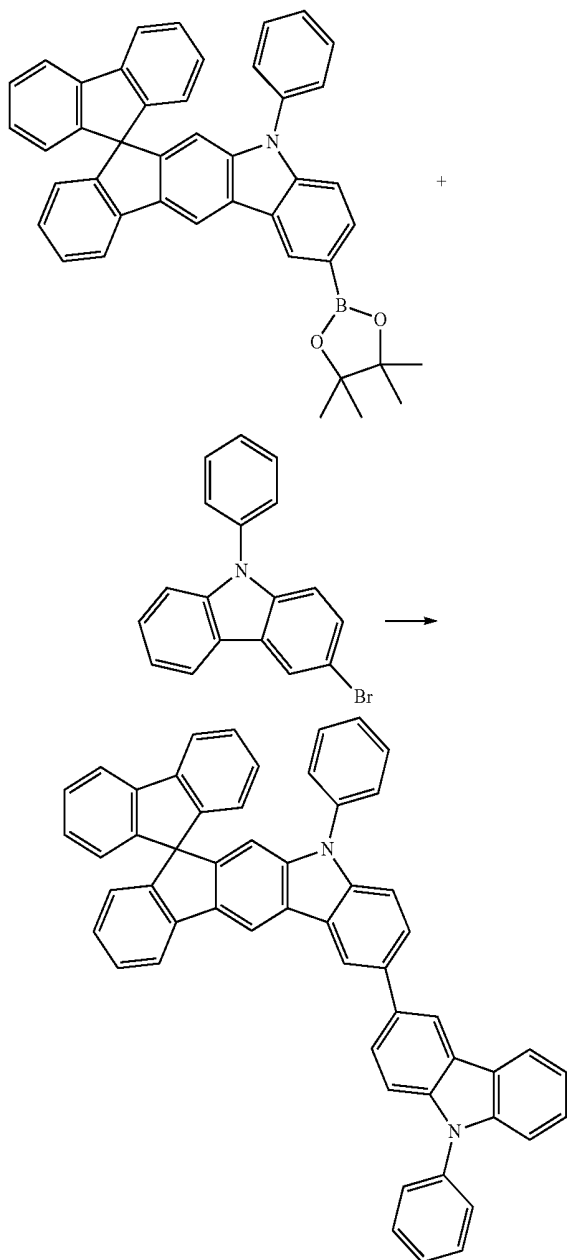

[0206] 3'-phenyl-6'-(4,4,5,5-tetramethyl-1,3,2-dioxaborolan-2-yl)-3'H-spiro[fluorene-9, 1'-inden[2,1-b]carbazole] (10 g, 19 mmol), 3-bromo-9-phenylcarbazole derivative (5 g, 16 mmol), Pd(PPh₃)₄ (0.2 g, 0.2 mmol) and potassium carbonate (5 g, 33 mmol) were suspended in a mixture of toluene (150 mL), ethylalcohol (50 mL) and distilled water (50 mL) and refluxed/stirred for 12 hours. The mixture was extracted by dichloromethane and distilled water, and the organic layer is filled in the silica-gel. After the resultant was distilled under the reduced pressure, the solid was recrystallized such that the compound PPH13 (6 g, yield: 50%) was obtained.

[0207] 8. Synthesis of the Compound PPH15

[0208] [Reaction Formula 8]

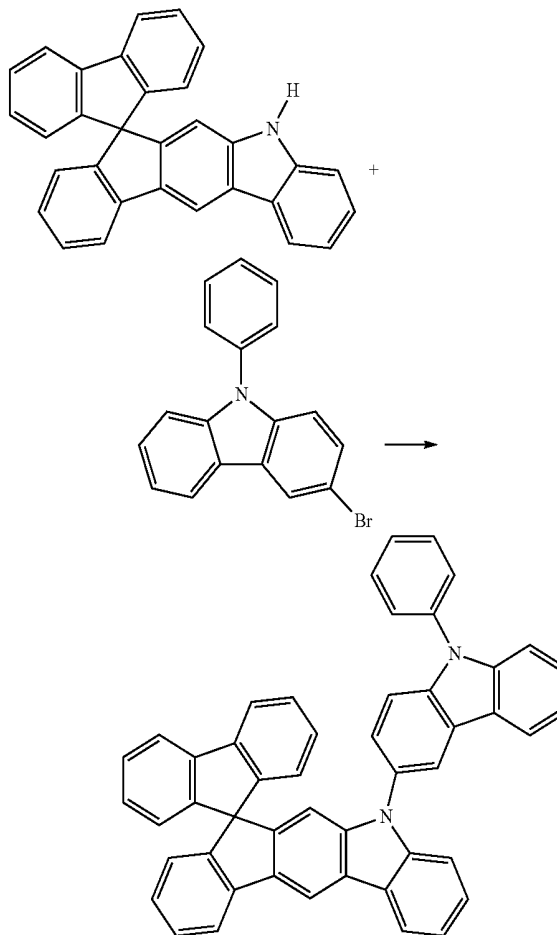

[0209] Spiro-bifluorene-indenocarbazole (12 g, 30 mmol), 3-bromo-9-phenylcarbazole (10 g, 30 mmol), sodium-tert-butoxide (6 g, 59 mmol), Pd₂(dba)₃ (1 g, 1.5 mmol) and tri-tert-butylphosphine (2 mL, 3 mmol) were suspended in xylene (1000 mL). The solution was refluxed and stirred for 12 hours. The resultant was extracted by dichloromethane and distilled water, and the organic layer was filled in the silica-gel. After removing the organic solvent, the resultant was columned in the silica-gel such that the compound PPH15 (12 g, yield: 63%) was obtained.

[0210] 9. Synthesis of the compound PNH1

(1) 2-(3-bromophenyl)-4,6-diphenyl-1,3,5-triazine

[0211] [Reaction Formula 9a]

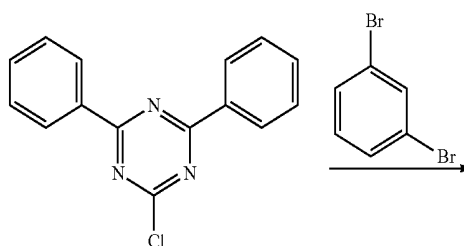

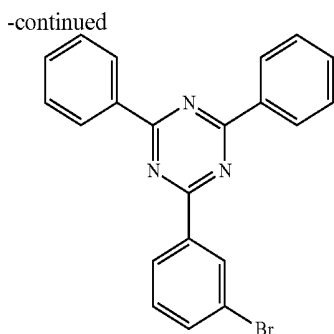

[0212] 1,3-dibromobenzene was dissolved in THF and cooled into the temperature of -78°C . n-BuLi (60 mL, 2.5M) was slowly dropped into the solution, and 2-chloro-4,6-diphenyl-1,3,5-triazine (40 g, 149.7 mmol), which is dissolved in THF, was slowly dropped. The solution was slowly heated up to the room temperature and stirred for 12 hours. After completion of the reaction, the resultant was re-precipitated by THF/MeOH and MC (methylenechloride)/hexane such that 2-(3-bromophenyl)-4,6-diphenyl-1,3,5-triazine (16 g, yield: 28%) was obtained.

(2) 2,4-diphenyl-6-(3-(4,4,5,5-tetramethyl-1,3,2-dioxaborolan-2-yl)phenyl)-1,3,5-triazine

[0213] [Reaction Formula 9b]

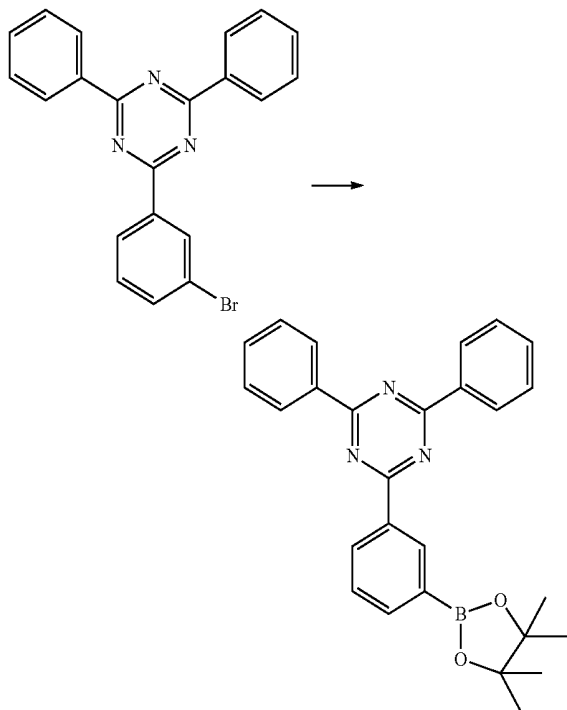

[0214] 2-(3-bromophenyl)-4,6-diphenyl-1,3,5-triazine (15.8 g, 40.7 mmol), bis(pinacolato)diboron (10.4 g, 40.71 mmol), Pd2(dba)3 (1.12 g, 1.2 mmol), potassium acetate (6.0 g, 61.1 mmol) and tricyclohexylphosphine (0.8 g, 2.8 mmol) were dissolved in 1,4-dioxane and refluxed/stirred for 12 hours. After completion of the reaction, the solvent was removed. After the mixture was dissolved in hot toluene, the resultant was filter in the silica-gel such that

2,4-diphenyl-6-(3-(4,4,5,5-tetramethyl-1,3,2-dioxaborolan-2-yl)phenyl)-1,3,5-triazine (13 g, yield: 73%) was obtained.

(3) 2-(3-(4,6-diphenyl-1,3,5-triazin-2-yl)phenyl)-5H-benzofuro[3,2-c]carbazole

[0215] [Reaction Formula 9c]

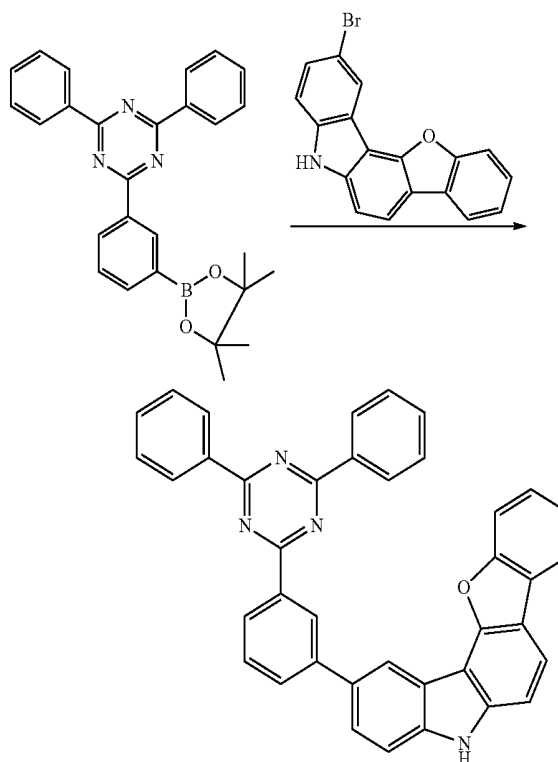

[0216] 2,4-diphenyl-6-(3-(4,4,5,5-tetramethyl-1,3,2-dioxaborolan-2-yl)phenyl)-1,3,5-triazine (3 g, 29.86 mmol), benzofuran-carbazole derivative (13.05 g, 38.82 mmol), Pd(pph3)4 (1.04 g, 0.896 mmol) and K2CO3 (12.4 g, 89.58 mmol) were dissolved in a mixture of ethyl alcohol (150 mL), distilled water (150 mL) and THF (300 mL) and stirred for 12 hours. After the solvent was removed, the resultant was re-precipitated by THF/MeOH such that 2-(3-(4,6-diphenyl-1,3,5-triazin-2-yl)phenyl)-5H-benzofuro[3,2-c]carbazole (11 g, 65%) was obtained.

(4) The Compound PNH1

[0217] [Reaction Formula 9d]

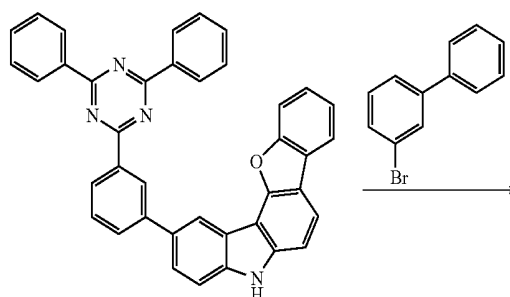

-continued

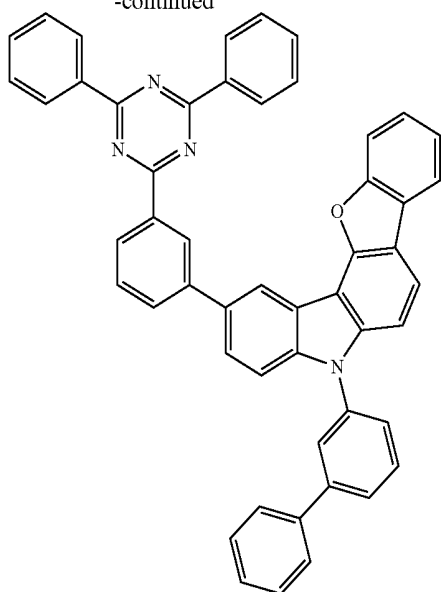

[0218] 2-(3-(4,6-diphenyl-1,3,5-triazin-2-yl)phenyl)-5H-benzofuro[3,2-c]carbazole (11 g, 19.48 mmol), bromo-biphenyl (5.45 g, 23.38 mmol), Pd2(dba)3 (0.7 g, 0.799 mmol), tert-butylphosphine (0.2 g, 1.169 mmol) and tert-sodiumbutoxide (4.5 g, 46.75 mmol) were dissolved in toluene. The mixture was refluxed/stirred for 12 hours. After completion of the reaction, the resultant was columned in the silica-gel such that the compound PNH1 (3.5 g, yield: 25%) was obtained.

[0219] 10. Synthesis of the compound PNH3

(1) 4-(2-nitrophenyl)dibenzo[b,d]furan

[0220] [Reaction Formula 10a]

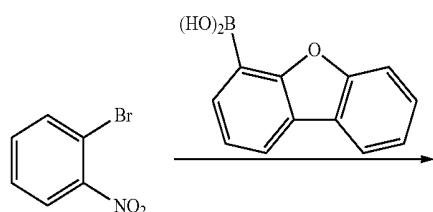

[0221] Bromonitrobenzene 20 g (99 mmol), dibenzofuran-1-yl-boronic acid (25.1 g, 118.8 mmol), Pd(pph3)4 (4.58 g, 3.96 mmol) and Na2CO3 (31.5 g, 297 mmol) were dissolved

in a mixture of ethyl alcohol (148 mL) and toluene (267 mL). The mixture was refluxed/stirred for 12 hours. After completion of the reaction, the resultant was extracted by distilled water and columned in a silica-gel such that 4-(2-nitrophenyl)dibenzo[b,d]furan (29.3 g, yield: 100%) was obtained.

(2) 5H-benzofuro[3,2-c]carbazole

[0222] [Reaction Formula 10b]

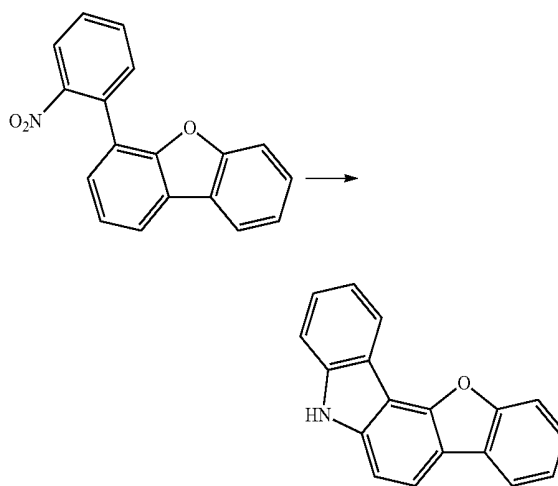

[0223] 4-(2-nitrophenyl)dibenzo[b,d]furan 29.3 g (101.3 mmol) and triphenylphosphine 66.4 g (253.2 mmol) were dissolved in dichlorobenzene (210 mL). The mixture was refluxed/stirred for 12 hours. After completion of the reaction, dichlorobenzene was removed. The resultant was columned in a silica-gel and washed by methyl alcohol such that 5H-benzofuro[3,2-c]carbazole (17 g, yield: 65%) was obtained.

(3) The Compound PNH3

[0224] [Reaction Formula 10c]

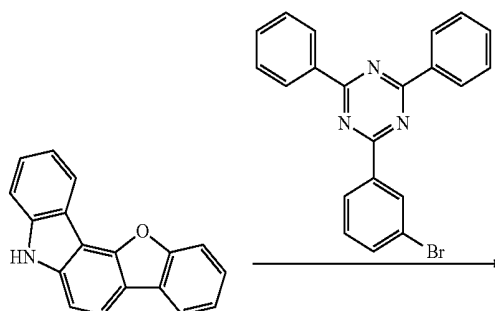

-continued

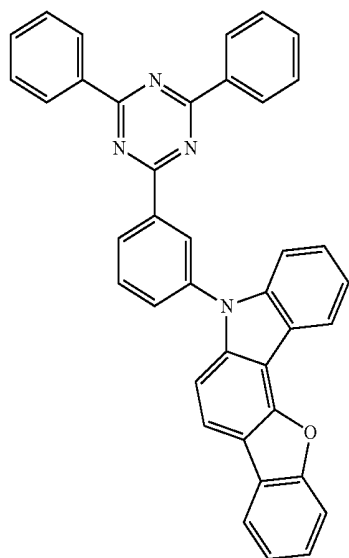

[0225] 5H-benzofuro[3,2-c]carbazole (5.1 g, 19.83 mmol), triazine derivative (7 g, 18.03 mmol), Pd2(dba)3 (0.66 g, 0.72 mmol), tert-Butyl phosphine (0.2 g, 1.08 mmol) and tert-sodiumbutoxide (3.8 g, 39.7 mmol) were dissolved in toluene (150 mL). The mixture was refluxed/stirred for 12 hours. After toluene was removed, the resultant was columned in a silica-gel such that the compound PNH3 (2 g, yield: 20%) was obtained.

[0226] 11. Synthesis of the Compound PNH5

[0227] [Reaction Formula 11]

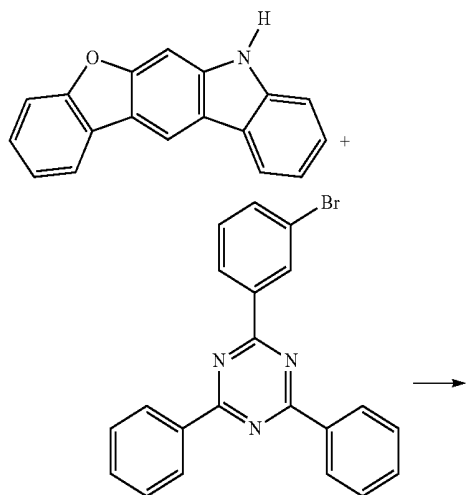

-continued

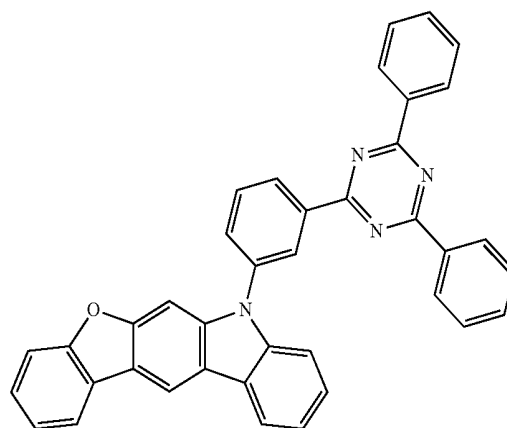

[0228] Benzofuro carbazole (15 g, 58 mmol), meta-bromophenyl triazine (23 g, 58 mmol), tert-sodiumbutoxide (11 g, 117 mmol), Pd2(dba)3 (3 g, 3 mmol) and tert-tributylphosphine (3 g, 6 mmol) were suspended in xylene (1000 mL). The solution was refluxed and stirred for 12 hours. The resultant was extracted by dichloromethane and distilled water, and the organic layer was filled in the silica-gel. After removing the organic solvent, the resultant was columned in the silica-gel such that the compound PNH5 (15 g, yield: 46%) was obtained.

[0229] 12. Synthesis of the Compound PNH7

[0230] [Reaction Formula 12]

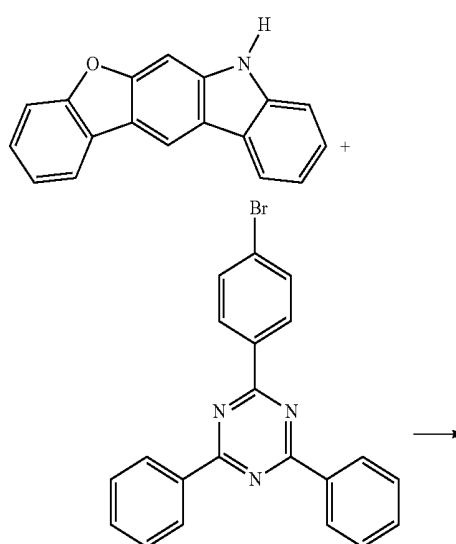

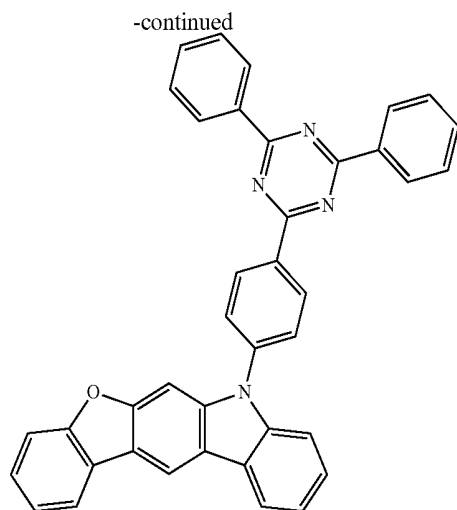

[0231] Benzofuro carbazole (15 g, 58 mmol), para-bromophenyl triazine (23 g, 58 mmol), tert-sodiumbutoxide (11 g, 117 mmol), Pd2(dba)3 (3 g, 3 mmol) and tert-tributylphosphine (3 g, 6 mmol) were suspended in xylene (1000 mL). The solution was refluxed and stirred for 12 hours. The resultant was extracted by dichloromethane and distilled water, and the organic layer was filled in the silica-gel. After removing the organic solvent, the resultant was columned in the silica-gel such that the compound PNH7 (17 g, yield: 52%) was obtained.

[0232] The related art host materials, each of which has Formulas of HOST1 and HOST2 below, were synthesized. (HOST1: 4-(3-(triphenylen-2-yl)phenyl)dibenzo[b,d]thiophene, HOST2: 3-(4,6-diphenyl-1,3,5-triazin-2-yl)-1-phenyl-1,3-dihydroindolo[2,3-b]carbazole)

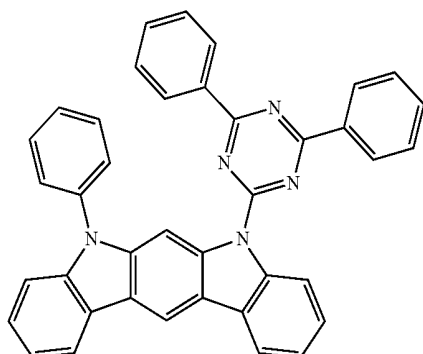
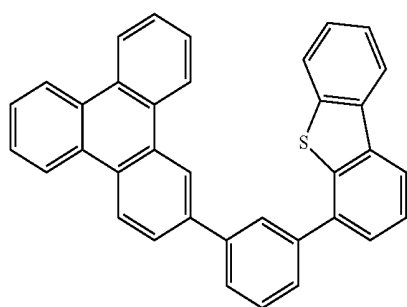

[0233] The properties, e.g., LUMO energy level, HOMO energy level and band gap energy, of the organic compound of the present invention (PPH1, PPH3, PPH5, PPH7, PPH9, PPH11, PPH13, PPH15, PNH1, PNH3, PNH5 and PNH7) and the compounds of HOST1 and HOST2 were measured and listed in Table 1.

TABLE 1

Compounds	Band gap Energy ^b (eV)	LUMO ^c (eV)	HOMO ^a (eV)
Host1	3.80	-2.20	-6.00
Host2	3.26	-2.23	-5.49
PPH1	3.30	-2.08	-5.38
PPH3	3.30	-2.05	-5.34
PPH5	3.28	-1.78	-5.06
PPH7	3.33	-2.01	-5.34
PPH9	3.28	-2.19	-5.47
PPH11	3.20	-2.04	-5.24
PPH13	3.19	-1.72	-4.91
PPH15	3.16	-1.70	-4.86
PNH1	3.34	-2.34	-5.68
PNH3	3.44	-2.29	-5.73
PNH5	3.54	-2.11	-5.65
PNH7	3.12	-2.51	-5.63

^a Absorption onset of 0.02 mM solutions in CH₂Cl₂.

^b Estimated from the absorption onset.

^c LUMO = -[Band gap energy - HOMO level]

[0234] As shown in Table 1, the band gap energy of the organic compound of the present invention is smaller than that of the HOST1 compound, while the band gap energy of the organic compound of the present invention is similar to or slightly larger than that of the HOST2 compound. Accordingly, the organic compound of the present invention has sufficient band gap energy for the host in the EML of the organic light emitting diode.

Organic Light Emitting Diode

1. EXAMPLE 1

[0235] An organic light emitting diode having a structure of ITO layer (a reflective anode), an HIL, an HTL1, an HTL2, an EBL, an EML, an ETL, an EIL, a cathode and a capping layer (CPL). A substrate, where an ITO layer including a reflection plate is patterned to form the anode (10 mm*40 mm and a thickness of 0.5 μm), is ultrasonically washed (or cleaned) by isopropyl alcohol, acetone and distilled water for 5 minutes and dried in the oven of the temperature of 100° C. After the substrate is treated by O₂ plasma for 2 minutes, the substrate is loaded in a deposition chamber. Under the vacuum of about 1*10⁻⁷ Torr, following layers are sequentially deposited using a sputtering boat.

[0236] (a) HIL: (HIL compound (3wt %) and HTL1 compound (97wt %), 100 Å),

[0237] (b) HTL1: (HTL1 compound, 1200 Å),

[0238] (c) HTL2: (HTL2 compound, 250 Å),

[0239] (d) EBL: (EBL compound, 150 Å),

[0240] (e) EML: (first host (PPH1), second host (HOST2) and G-dopant (D7 compound in above Formula 10, 5wt % doping), (first host:second host=1:1), 400 Å),

[0241] f) ETL: (ETL compound/Liq (wt % ratio=2:1), 300 Å),

[0242] (g) EIL (Mg/LiF (wt % ratio=3:1, 30 Å),

[0243] (h) cathode (Ag/Mg (wt % ratio=4:1, 140 Å) and

[0244] (i) CPL

[0245] The deposited structure is loaded in the drying box and encapsulated by an UV-cured epoxy and a getter. The organic light emitting diode has an emitting area of 9 mm². The Formulas of the compound HIL, the compound HTL1, the compound HTL2, the compound EBL, the compound ETL and the compound Liq are shown below.

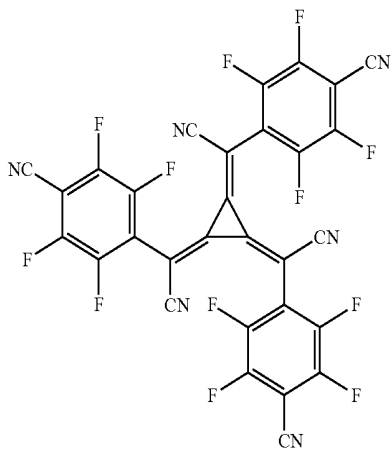

HIL

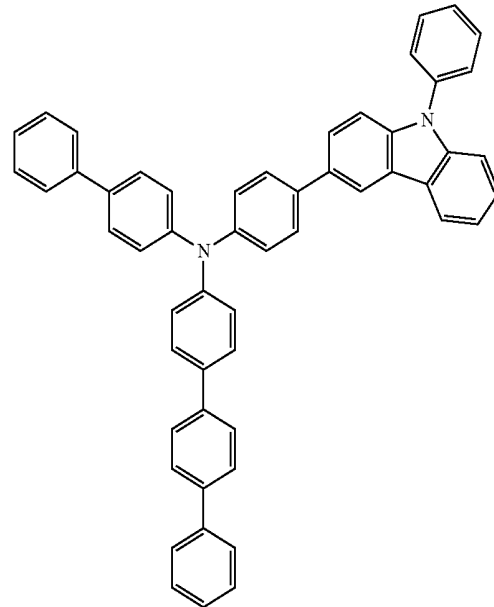

HTL2

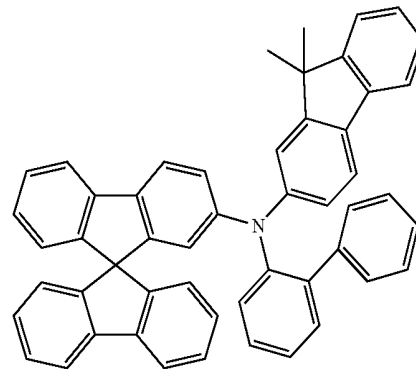

EBL

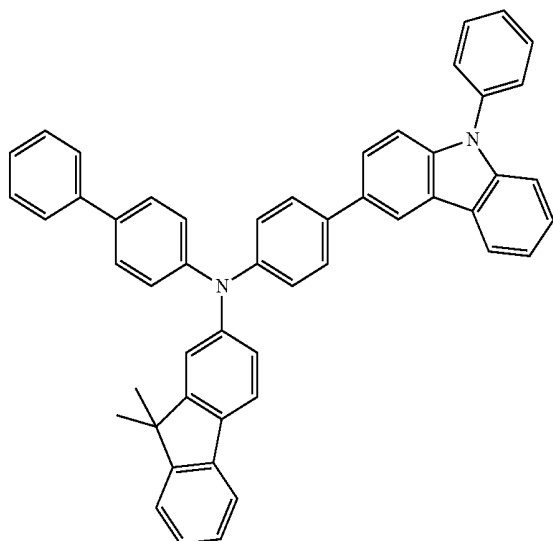

HTL1

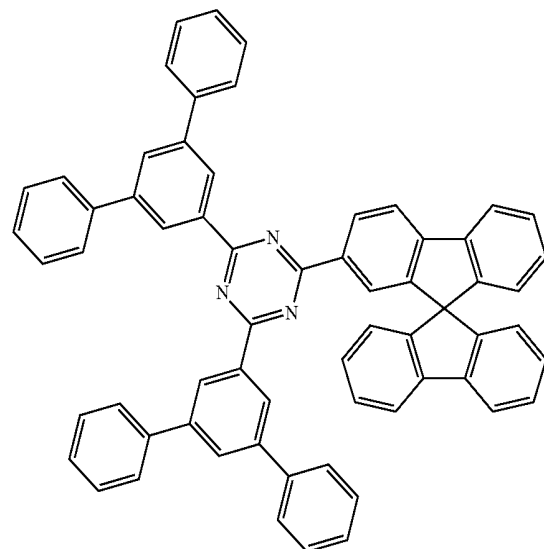

ETL

-continued

-continued

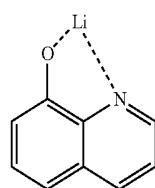

Liq

2. EXAMPLES 2 TO 16

EX2 TO EX16

[0246] Instead of the first host and the second host, the compound PPH5 and the compound HOST2 (Ex2), the compound HOST1 and the compound PNH1 (Ex3), the compound HOST1 and the compound PNH3 (Ex4), the compound HOST1 and the compound PNH5 (Ex5), the compound HOST1 and the compound PNH7 (Ex6), the compound PPH1 and the compound PNH1 (Ex7), the compound PPH1 and the compound PNH7 (Ex8), the compound PPH5 and the compound PNH1 (Ex9), the compound PPH5 and the compound PNH7 (Ex10), the compound PPH3 and the compound PNH7 (Ex11), the compound PPH7 and the compound PNH7 (Ex12), the compound PPH9 and the compound PNH7 (Ex13), the compound PPH13 and the compound PNH7 (Ex14), the compound PPH15 and the compound PNH7 (Ex15) and the compound PPH1 and the compound PNH5 (Ex16) are respectively used.

3. COMPARATIVE EXAMPLE 1

Ref1

[0247] Instead of the first host and the second host, the compound HOST1 and the compound HOST2 are used.

[0248] The EL property of the organic light emitting diode in "Example 1" to "Example 16" and "Comparative Example 1" is measured using the current supply "KEITHLEY" and the photometer "PR 650" under the room temperature and listed in Table 2. The driving voltage, the efficiency (Cd/A) and the CIE color coordinate index of the organic light emitting diodes are measured with a reference luminance of 8000 nit, and the lifetime (T95) from 100% to 95% are measured with 20000 nit reference luminance constant current.

TABLE 2

	V	Cd/A	CIE(x, y)	T95 [hr]
Ref1	4.75	131.4	0.196, 0.725	190
Ex1	4.10	135.0	0.216, 0.723	240
Ex2	4.03	133.7	0.244, 0.709	200
Ex3	4.49	115.2	0.270, 0.703	280
Ex4	4.54	119.3	0.276, 0.710	190
Ex5	4.18	131.4	0.196, 0.725	170
Ex6	4.09	156.4	0.217, 0.725	250
Ex7	4.10	138.5	0.237, 0.729	420
Ex8	4.06	146.3	0.231, 0.724	350
Ex9	4.05	148.2	0.226, 0.726	480
Ex10	4.08	145.2	0.222, 0.723	380
Ex11	4.10	142.3	0.226, 0.727	300
Ex12	4.15	140.5	0.221, 0.713	330
Ex13	4.07	144.2	0.220, 0.726	340
Ex14	4.11	132.4	0.230, 0.715	280

TABLE 2-continued

	V	Cd/A	CIE(x, y)	T95 [hr]
Ex15	4.27	133.0	0.241, 0.709	290
Ex16	4.15	137.4	0.221, 0.715	320

[0249] As shown in Table 2, in comparison to "Comparative Example 1 (Ref)", the driving voltage of the organic light emitting diode of the present invention (Ex1 to Ex16) is reduced.

[0250] For example, when the PPH1 compound as a P-type host, the PPH5 compound as a P-type host or the PNH1 compound as an N-type host is used with the related art host material, i.e., HOST1 compound or HOST2 compound, the emitting efficiency and the lifetime of the organic light emitting diode are further improved.

[0251] In addition, when the first organic compound and the second organic compound of the present invention are used for the two-host system (Ex7 to Ex16), there are remarkable advantages in the driving voltage, the efficiency and the lifetime of the organic light emitting diode.

[0252] It will be apparent to those skilled in the art that various modifications and variations can be made in the present invention without departing from the spirit or scope of the invention. Thus, it is intended that the present invention cover the modifications and variations of this invention provided they come within the scope of the appended claims and their equivalents.

What is claimed is:

1. An organic compound, represented by following Formula 1:

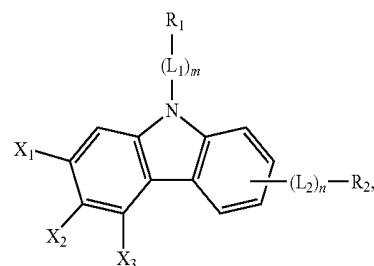

[Formula 1]

wherein R_1 is independently selected from the group consisting of substituted C_5 to C_{30} aryl group, non-substituted C_5 to C_{30} aryl group, substituted C_5 to C_{30} heteroaryl group, non-substituted C_5 to C_{30} heteroaryl group, substituted C_6 to C_{30} arylalkyl group, non-substituted C_6 to C_{30} arylalkyl group, substituted C_6 to C_{30} hetero-arylalkyl group, non-substituted C_6 to C_{30} hetero-arylalkyl group, non-substituted C_6 to C_{30} aryloxy group, substituted C_6 to C_{30} hetero-aryloxy group, and non-substituted C_6 to C_{30} hetero-aryloxy group, and

R_2 is independently selected from the group consisting of hydrogen, deuterium, tritium, substituted C_5 to C_{30} aryl group, non-substituted C_5 to C_{30} aryl group, substituted C_5 to C_{30} heteroaryl group, non-substituted C_5 to C_{30} heteroaryl group, substituted C_6 to C_{30} arylalkyl group, non-substituted C_6 to C_{30} arylalkyl group, substituted C_6 to C_{30} hetero-arylalkyl group, non-substituted C_6 to C_{30} hetero-arylalkyl group, non-substituted C_6 to C_{30}

aryloxy group, substituted C₆ to C₃₀ hetero-aryloxy group, and non-substituted C₆ to C₃₀ hetero-aryloxy group,

wherein each of L₁ and L₂ is independently selected from the group consisting of substituted C₁ to C₃₀ alkylene group, non-substituted C₁ to C₃₀ alkylene group, substituted C₃ to C₃₀ cyclo-alkylene group, non-substituted C₃ to C₃₀ cyclo-alkylene group, substituted C₅ to C₃₀ arylene group, non-substituted C₅ to C₃₀ arylene group, substituted C₄ to C₃₀ heteroarylene group, non-substituted C₄ to C₃₀ heteroarylene group, substituted C₆ to C₃₀ arylalkylene group, non-substituted C₆ to C₃₀ arylalkylene group, substituted C₆ to C₃₀ hetero-arylalkylene group, non-substituted C₆ to C₃₀ hetero-arylalkylene group, substituted C₆ to C₃₀ aryloxy group, non-substituted C₆ to C₃₀ aryloxy group, substituted C₆ to C₃₀ hetero-aryloxy group, and non-substituted C₆ to C₃₀ hetero-aryloxy group, and each of m and n is 0 or 1, and

wherein X₂ with one of X₁ and X₃ forms a C₄ to C₃₀ homo fused-ring or a C₄ to C₃₀ hetero fused-ring, and the other one of X₁ and X₃ is selected from the group consisting of hydrogen, deuterium, tritium, substituted C₁ to C₂₀ alkyl group, non-substituted C₁ to C₂₀ alkyl group, substituted C₁ to C₂₀ alkoxy group, non-substituted C₁ to C₂₀ alkoxy group, substituted C₅ to C₃₀ aryl group, non-substituted C₅ to C₃₀ aryl group, substituted C₅ to C₃₀ heteroaryl group, and non-substituted C₅ to C₃₀ heteroaryl group.

2. The organic compound according to claim 1, wherein the Formula 1 is represented by one of following Formula 2:

[Formula 2]

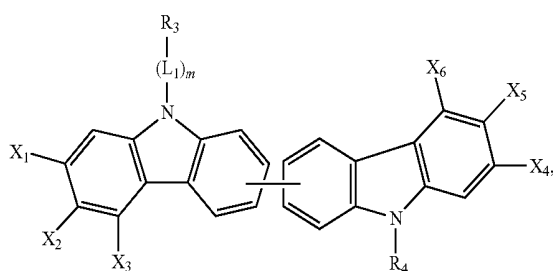

wherein each of R₃ and R₄ is independently selected from the group consisting of hydrogen, deuterium, tritium, C₅ to C₃₀ aryl group, substituted C₅ to C₃₀ heteroaryl group, non-substituted C₅ to C₃₀ heteroaryl group, substituted C₆ to C₃₀ arylalkyl group, non-substituted C₆ to C₃₀ arylalkyl group, substituted C₆ to C₃₀ hetero-arylalkyl group, non-substituted C₆ to C₃₀ hetero-arylalkyl group, non-substituted C₆ to C₃₀ aryloxy group, substituted C₆ to C₃₀ hetero-aryloxy group, and non-substituted C₆ to C₃₀ hetero-aryloxy group,

wherein X₅ with one of X₄ and X₆ forms a C₄ to C₃₀ homo fused-ring or a C₄ to C₃₀ hetero fused-ring, or each of X₄ to X₆ is selected from the group consisting of hydrogen, deuterium, tritium, substituted C₁ to C₂₀ alkyl group, non-substituted C₁ to C₂₀ alkyl group, substituted C₁ to C₂₀ alkoxy group, non-substituted C₁

to C₂₀ alkoxy group, substituted C₅ to C₃₀ aryl group, non-substituted C₅ to C₃₀ aryl group, substituted C₅ to C₃₀ heteroaryl group, and non-substituted C₅ to C₃₀ heteroaryl group,

wherein L₁ is selected from the group consisting of substituted C₁ to C₃₀ alkylene group, non-substituted C₁ to C₃₀ alkylene group, substituted C₃ to C₃₀ cyclo-alkylene group, non-substituted C₃ to C₃₀ cyclo-alkylene group, substituted C₅ to C₃₀ arylene group, non-substituted C₅ to C₃₀ arylene group, substituted C₄ to C₃₀ heteroarylene group, non-substituted C₄ to C₃₀ heteroarylene group, substituted C₆ to C₃₀ arylalkylene group, non-substituted C₆ to C₃₀ arylalkylene group, substituted C₆ to C₃₀ hetero-arylalkylene group, non-substituted C₆ to C₃₀ hetero-arylalkylene group, substituted C₆ to C₃₀ aryloxy group, non-substituted C₆ to C₃₀ aryloxy group, substituted C₆ to C₃₀ hetero-aryloxy group, and non-substituted C₆ to C₃₀ hetero-aryloxy group, and m is 0 or 1, and

wherein X₂ with one of X₁ and X₃ forms a C₄ to C₃₀ homo fused-ring or a C₄ to C₃₀ hetero fused-ring, and the other one of X₁ and X₃ is selected from the group consisting of hydrogen, deuterium, tritium, substituted C₁ to C₂₀ alkyl group, non-substituted C₁ to C₂₀ alkyl group, substituted C₁ to C₂₀ alkoxy group, non-substituted C₁ to C₂₀ alkoxy group, substituted C₅ to C₃₀ aryl group, non-substituted C₅ to C₃₀ aryl group, substituted C₅ to C₃₀ heteroaryl group, and non-substituted C₅ to C₃₀ heteroaryl group.

3. The organic compound according to claim 2, wherein the organic compound is selected from:

PPHI

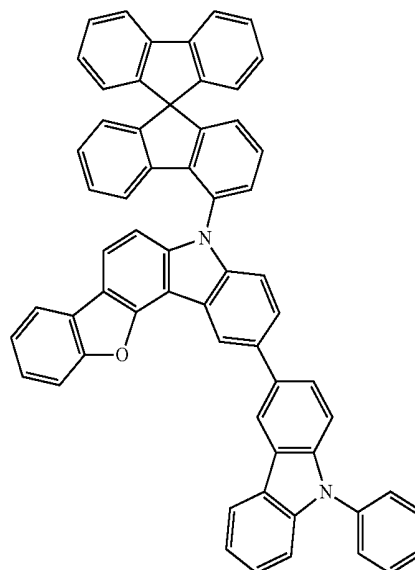

-continued

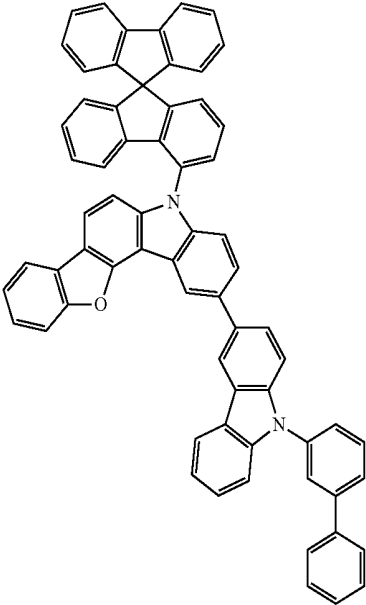

PPH2

-continued

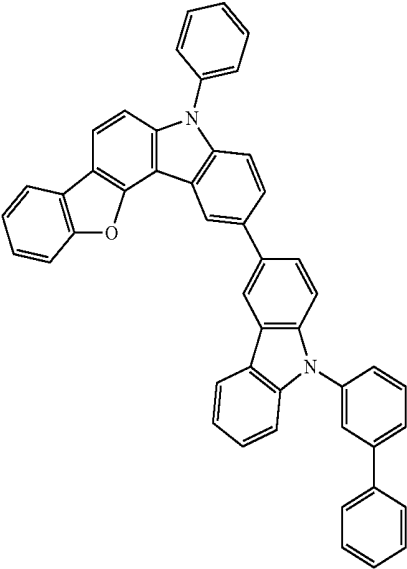

PPH4

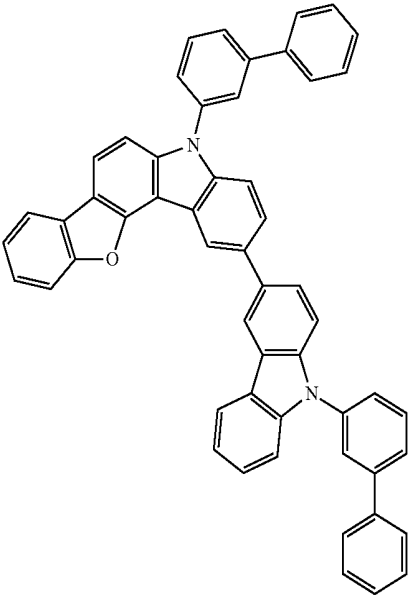

PPH3

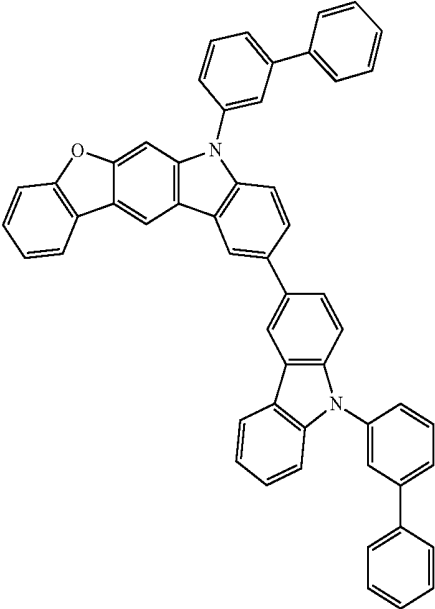

PPH5

-continued

-continued

PPH6

PPH8

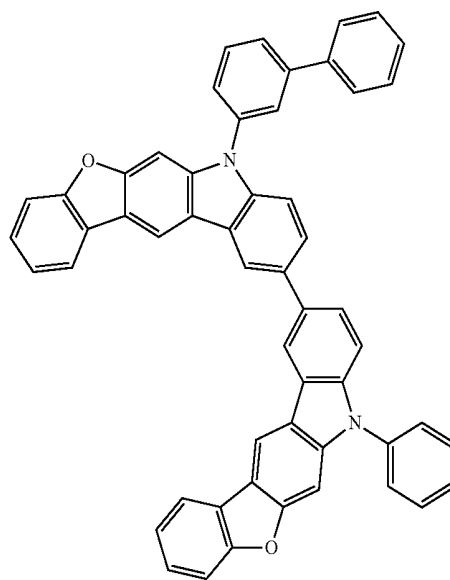
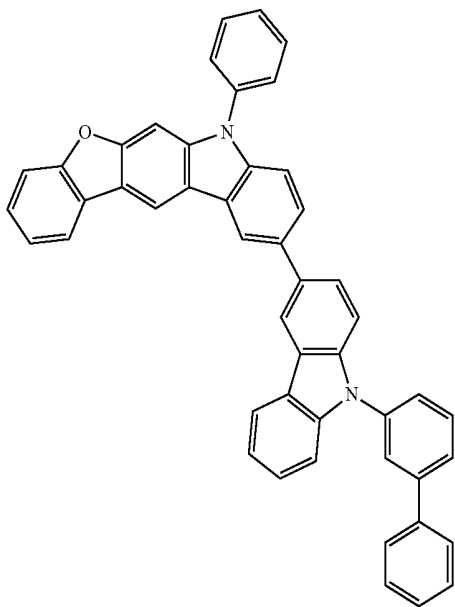

PPH7

PPH9

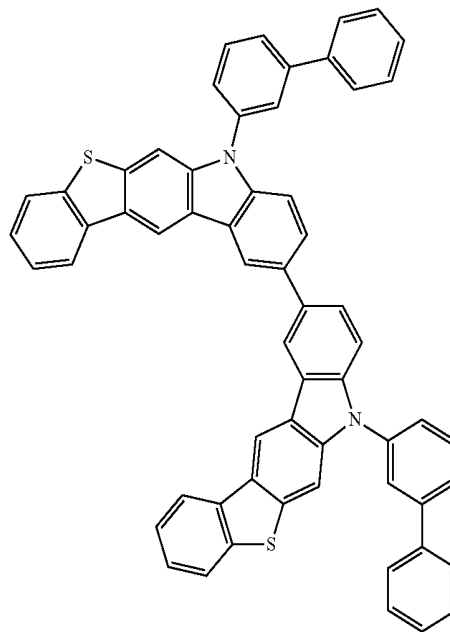
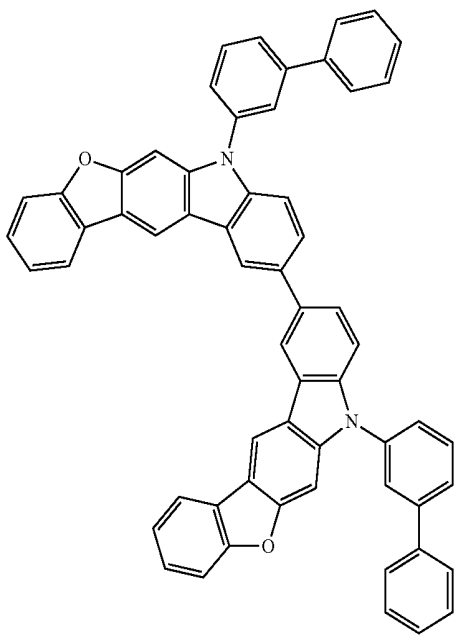

-continued

PPH10

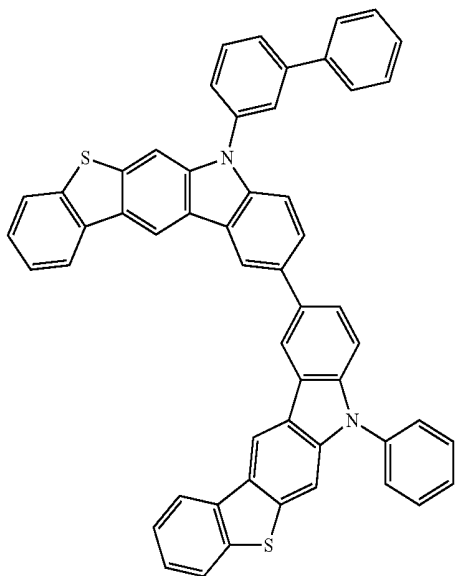

-continued

PPH13

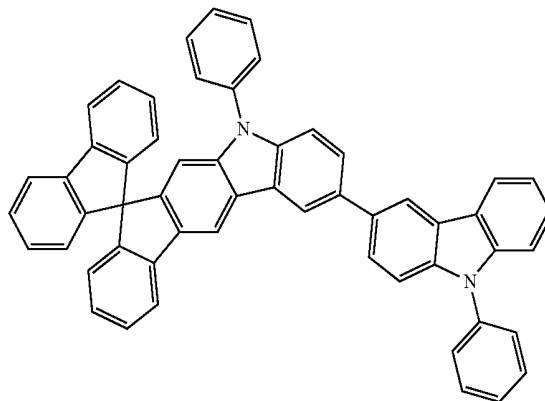

PPH11

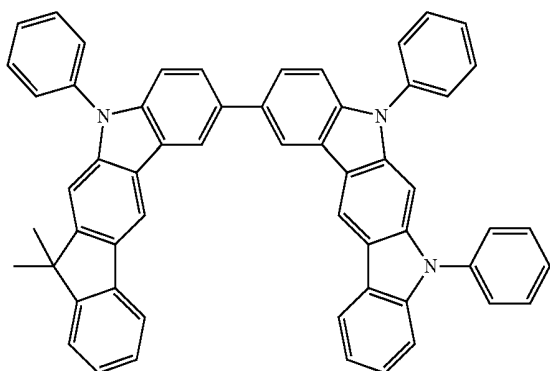

PPH12

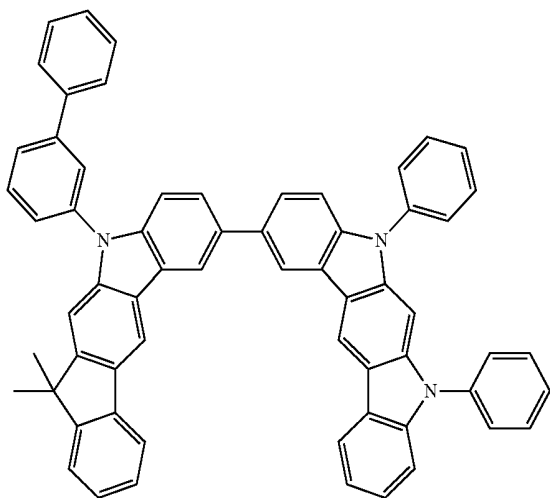

PPH14

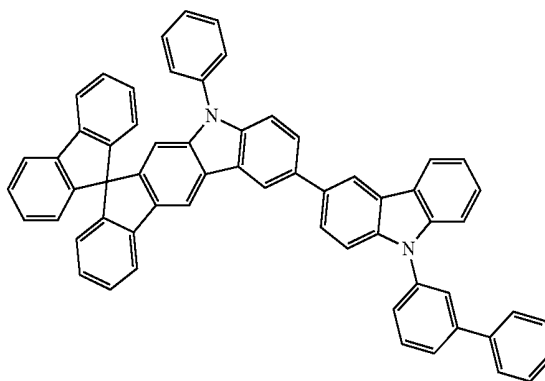

PPH15

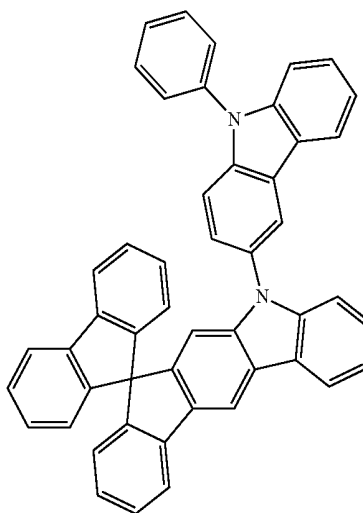

-continued

PPH16

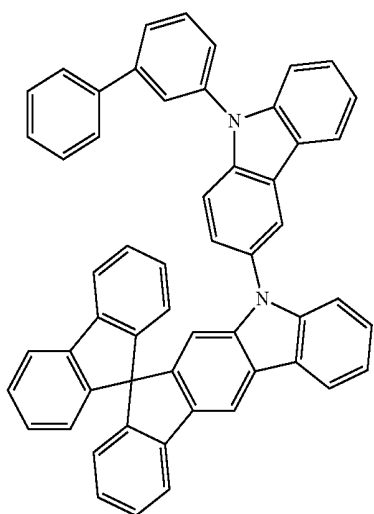

4. The organic compound according to claim 1, wherein the Formula 1 is represented by one of following Formulas 3a or 3b:

[Formula 3a]

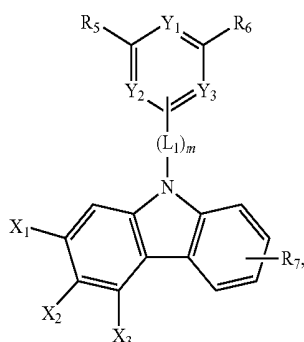

wherein each of R_5 to R_7 is independently selected from the group consisting of hydrogen, deuterium, tritium, C_5 to C_{30} aryl group, substituted C_5 to C_{30} heteroaryl group, non-substituted C_5 to C_{30} heteroaryl group, substituted C_6 to C_{30} arylalkyl group, non-substituted C_6 to C_{30} arylalkyl group, substituted C_6 to C_{30} hetero-arylalkyl group, non-substituted C_6 to C_{30} hetero-arylalkyl group, non-substituted C_6 to C_{30} hetero-arylalkyl group, substituted C_6 to C_{30} aryloxy group, and non-substituted C_6 to C_{30} hetero-aryloxy group,

wherein each of Y_1 to Y_3 is independently N or CR_8 , and at least one of Y_1 to Y_3 is N,

wherein R_8 is selected from the group consisting of hydrogen, deuterium, tritium, C_5 to C_{30} aryl group, substituted C_5 to C_{30} heteroaryl group, non-substituted C_5 to C_{30} heteroaryl group, substituted C_6 to C_{30} arylalkyl group, non-substituted C_6 to C_{30} arylalkyl group, substituted C_6 to C_{30} hetero-arylalkyl group, non-substituted C_6 to C_{30} hetero-arylalkyl group, non-substituted C_6 to C_{30} hetero-arylalkyl group, substituted C_6 to C_{30} aryloxy group, substituted C_6 to C_{30} hetero-aryloxy group, and non-substituted C_6 to C_{30} hetero-aryloxy group,

[Formula 3b]

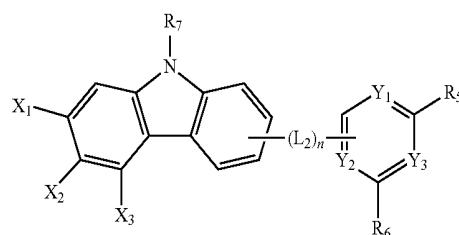

wherein L_1 is selected from the group consisting of substituted C_1 to C_{30} alkylene group, non-substituted C_1 to C_{30} alkylene group, substituted C_3 to C_{30} cycloalkylene group, non-substituted C_3 to C_{30} cycloalkylene group, substituted C_5 to C_{30} arylene group, non-substituted C_5 to C_{30} arylene group, substituted C_4 to C_{30} heteroarylene group, non-substituted C_4 to C_{30} heteroarylene group, substituted C_6 to C_{30} arylalkylene group, non-substituted C_6 to C_{30} arylalkylene group, substituted C_6 to C_{30} hetero-arylalkylene group, non-substituted C_6 to C_{30} hetero-arylalkylene group, substituted C_6 to C_{30} aryloxy group, non-substituted C_6 to C_{30} aryloxy group, substituted C_6 to C_{30} hetero-aryloxy group, and non-substituted C_6 to C_{30} hetero-aryloxy group, and m is 0 or 1, and wherein X_2 with one of X_1 and X_3 forms a C_4 to C_{30} homo fused-ring or a C_4 to C_{30} hetero fused-ring, and the other one of X_1 and X_3 is selected from the group consisting of hydrogen, deuterium, tritium, substituted C_1 to C_{20} alkyl group, non-substituted C_1 to C_{20} alkyl group, substituted C_1 to C_{20} alkoxy group, non-substituted C_1 to C_{20} alkoxy group, substituted C_5 to C_{30} aryl group, non-substituted C_5 to C_{30} aryl group, substituted C_5 to C_{30} heteroaryl group, and non-substituted C_5 to C_{30} heteroaryl group, and

wherein each of R_5 to R_7 is independently selected from the group consisting of hydrogen, deuterium, tritium, C_5 to C_{30} aryl group, substituted C_5 to C_{30} heteroaryl group, non-substituted C_5 to C_{30} heteroaryl group, substituted C_6 to C_{30} arylalkyl group, non-substituted C_6 to C_{30} arylalkyl group, substituted C_6 to C_{30} hetero-arylalkyl group, non-substituted C_6 to C_{30} hetero-arylalkyl group, non-substituted C_6 to C_{30} hetero-arylalkyl group, substituted C_6 to C_{30} aryloxy group, and non-substituted C_6 to C_{30} hetero-aryloxy group,

wherein each of Y_1 to Y_3 is independently N or CR_8 , and at least one of Y_1 to Y_3 is N,

wherein R_8 is selected from the group consisting of hydrogen, deuterium, tritium, C_5 to C_{30} aryl group, substituted C_5 to C_{30} heteroaryl group, non-substituted C_5 to C_{30} heteroaryl group, substituted C_6 to C_{30} arylalkyl group, non-substituted C_6 to C_{30} arylalkyl group, substituted C_6 to C_{30} hetero-arylalkyl group, non-substituted C_6 to C_{30} hetero-arylalkyl group, non-substituted C_6 to C_{30} hetero-arylalkyl group, substituted C_6 to C_{30} aryloxy group, substituted C_6 to C_{30} hetero-aryloxy group, and non-substituted C_6 to C_{30} hetero-aryloxy group,

wherein X_2 with one of X_1 and X_3 forms a C_4 to C_{30} homo fused-ring or a C_4 to C_{30} hetero fused-ring, and the other one of X_1 and X_3 is selected from the group consisting of hydrogen, deuterium, tritium, substituted

C_1 to C_{20} alkyl group, non-substituted C_1 to C_{20} alkyl group, substituted C_1 to C_{20} alkoxy group, non-substituted C_1 to C_{20} alkoxy group, substituted C_5 to C_{30} aryl group, non-substituted C_5 to C_{30} aryl group, substituted C_5 to C_{30} heteroaryl group, and non-substituted C_5 to C_{30} heteroaryl group, and

wherein L_2 is selected from the group consisting of substituted C_1 to C_{30} alkylene group, non-substituted C_1 to C_{30} alkylene group, substituted C_3 to C_{30} cyclo-alkylene group, non-substituted C_3 to C_{30} cyclo-alkylene group, substituted C_5 to C_{30} arylene group, non-substituted C_5 to C_{30} arylene group, substituted C_4 to C_{30} heteroarylene group, non-substituted C_4 to C_{30} heteroarylene group, substituted C_6 to C_{30} arylalkylene group, non-substituted C_6 to C_{30} arylalkylene group, substituted C_6 to C_{30} hetero-arylalkylene group, non-substituted C_6 to C_{30} hetero-arylalkylene group, substituted C_6 to C_{30} aryloxylyene group, non-substituted C_6 to C_{30} aryloxylyene group, substituted C_6 to C_{30} hetero-aryloxylyene group, and non-substituted C_6 to C_{30} hetero-aryloxylyene group, and n is 0 or 1.

5. The organic compound according to claim 4, wherein the organic compound is selected from:

-continued

PNH3

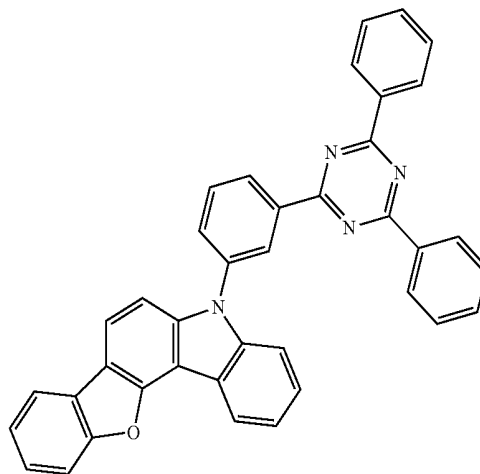

PNH1

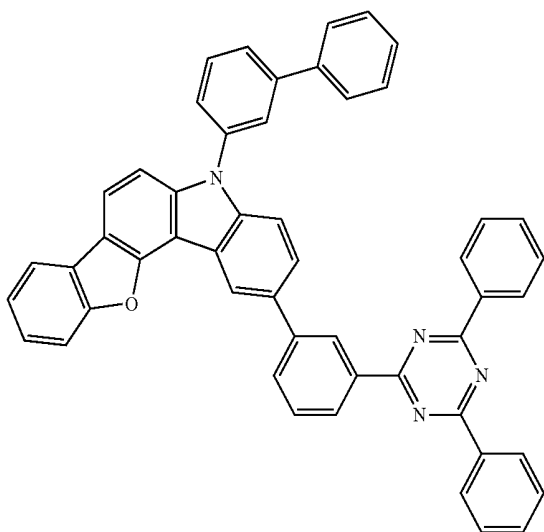

PNH2

PNH4

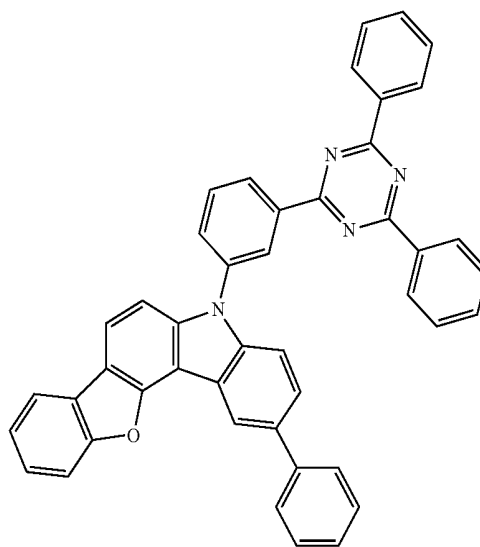

PNH5

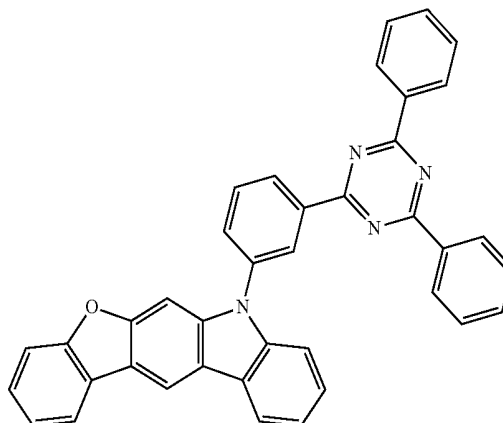
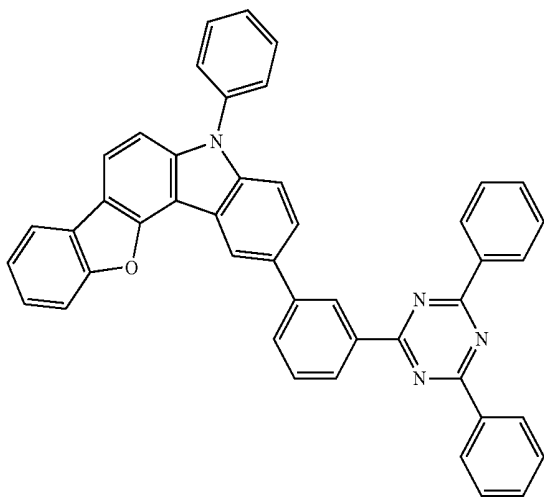

-continued

PNH6

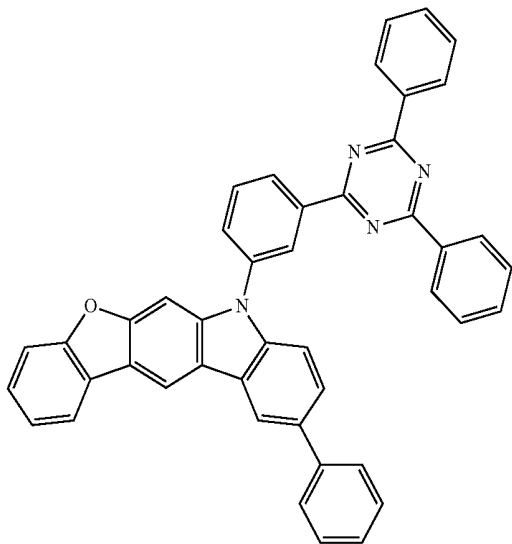

-continued

PNH9

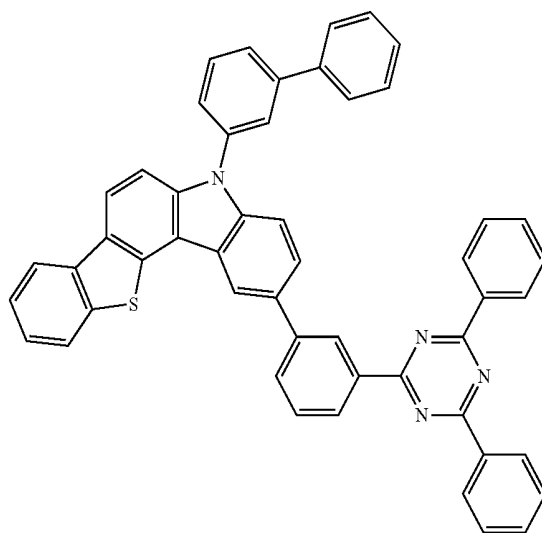

PNH7

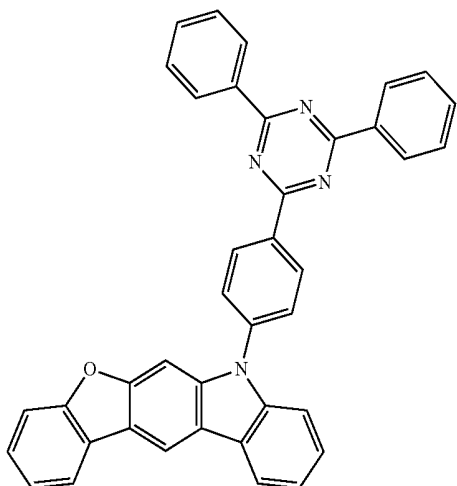

PNH10

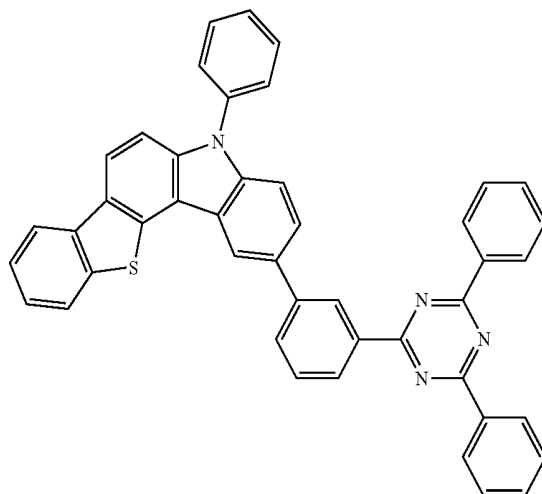

PNH8

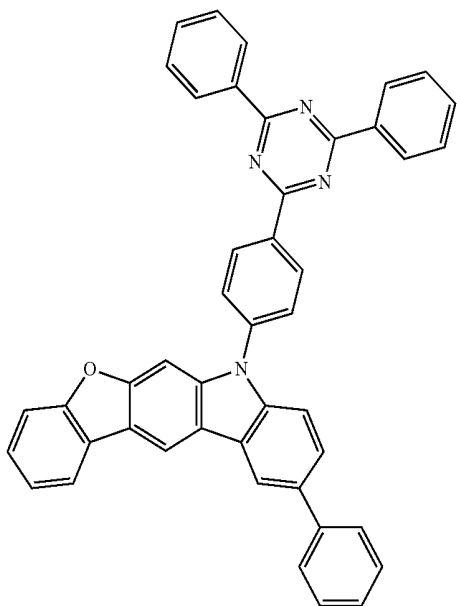

PNH11

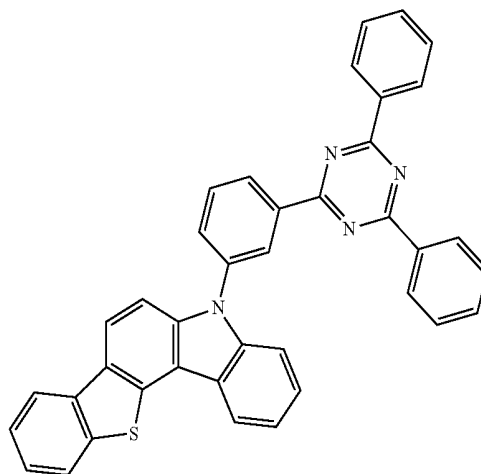

-continued

PNH12

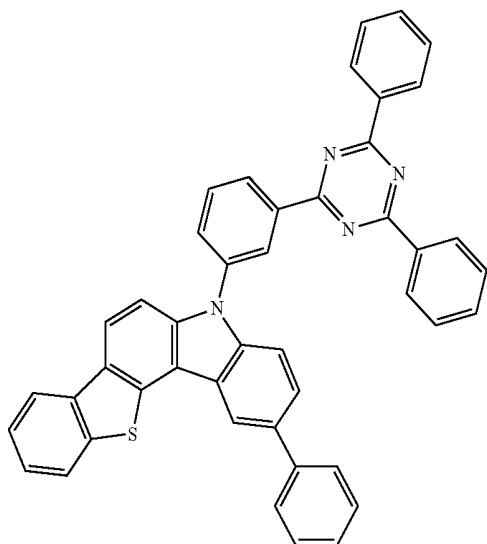

-continued

PNH15

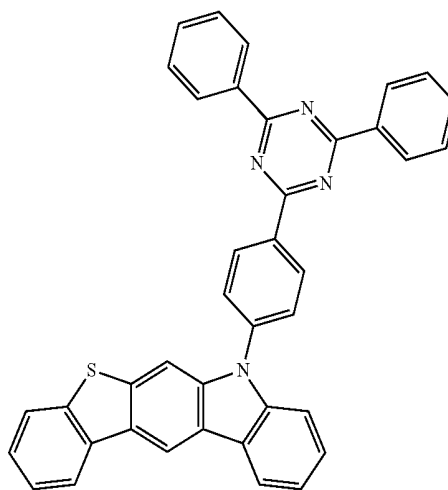

PNH16

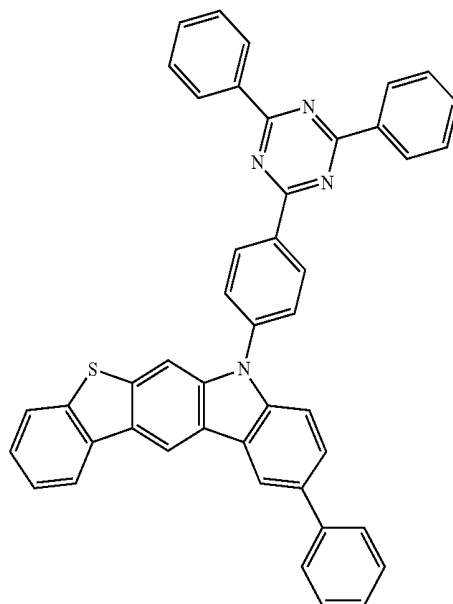

PNH13

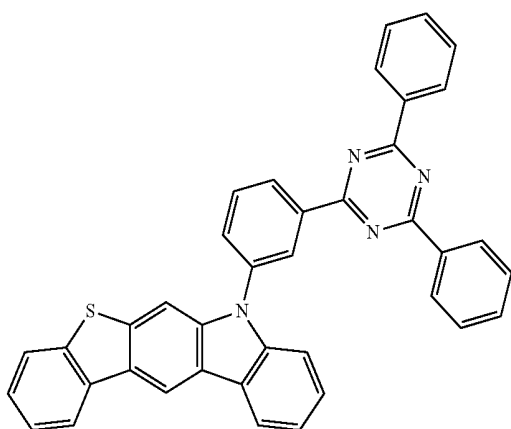

PNH14

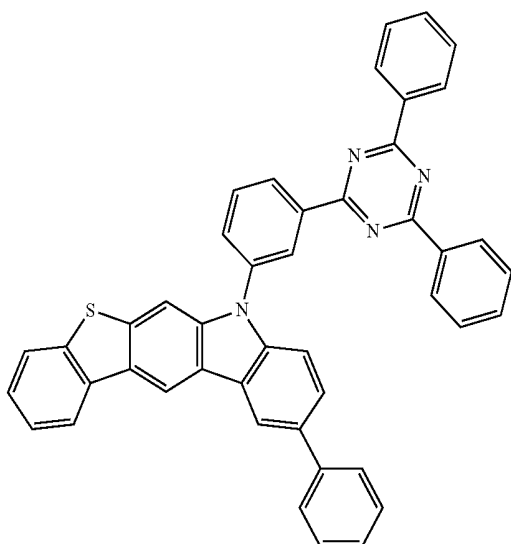

6. An organic light emitting diode, comprising:

a first electrode;

a second electrode facing the first electrode; and

an organic layer between the first electrode and the second electrode, wherein the organic layer includes the organic compound of claim 1.

7. The organic light emitting diode according to claim 6, wherein the organic layer includes an emitting material layer, a hole auxiliary layer between the first electrode and the emitting material layer and an electron auxiliary layer between the second electrode and the emitting material layer.

8. The organic light emitting diode according to claim 7, wherein the emitting material layer includes the organic compound as a host.

9. The organic light emitting diode according to claim 8, wherein the emitting material layer further includes a dopant represented by following Formulas 4a or 4b:

[Formula 4a]

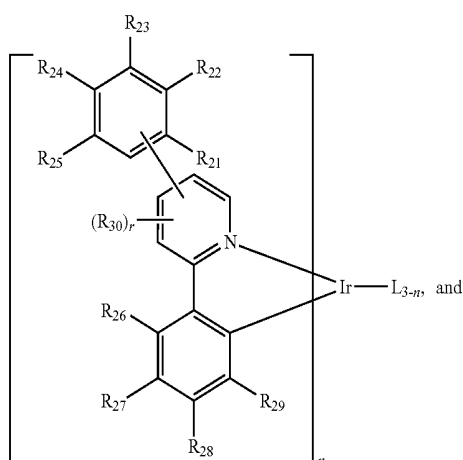

[Formula 4b]

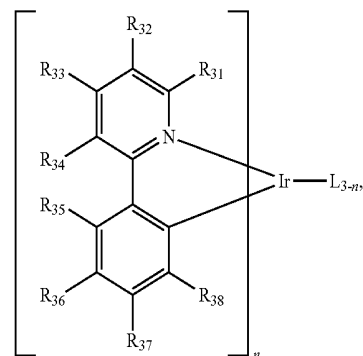

wherein in Formula 4a, each of R_{21} to R_{29} is independently selected from the group consisting of hydrogen, deuterium, tritium, halogen, substituted C_1 to C_{30} alkyl group, non-substituted C_1 to C_{30} alkyl group, cyano group, substituted C_3 to C_{30} cyclo-alkyl group, non-substituted C_3 to C_{30} cyclo-alkyl group, substituted C_3 to C_{30} hetero cyclo-alkyl group, non-substituted C_3 to C_{30} hetero cyclo-alkyl group, substituted C_5 to C_{30} aryl group, non-substituted C_5 to C_{30} aryl group, substituted C_5 to C_{30} heteroaryl group, non-substituted C_5 to C_{30} heteroaryl group, substituted C_6 to C_{30} arylalkyl group, non-substituted C_6 to C_{30} arylalkyl group, substituted C_6 to C_{30} hetero-arylalkyl group, non-substituted C_6 to C_{30} hetero-arylalkyl group, substituted C_6 to C_{30} aryloxy group, non-substituted C_6 to C_{30} aryloxy group, substituted C_6 to C_{30} hetero-aryloxy group, and non-substituted C_6 to C_{30} hetero-aryloxy group,

wherein R_{30} is selected from the group consisting of hydrogen, deuterium, tritium and substituted C_1 to C_{30} alkyl group, and non-substituted C_1 to C_{30} alkyl group, and r is an integer of 1 to 4,

wherein in Formula 4b, each of R_{31} to R_{38} is independently selected from the group consisting of hydrogen, deuterium, tritium, halogen, substituted C_1 to C_{30} alkyl group, non-substituted C_1 to C_{30} alkyl group, cyano group, substituted C_3 to C_{30} cyclo-alkyl group, non-substituted C_3 to C_{30} cyclo-alkyl group, substituted C_3 to C_{30} hetero cyclo-alkyl group, non-substituted C_3 to C_{30} hetero cyclo-alkyl group, substituted C_5 to C_{30} aryl group, non-substituted C_5 to C_{30} aryl group, substituted

C_5 to C_{30} heteroaryl group, non-substituted C_5 to C_{30} heteroaryl group, substituted C_6 to C_{30} arylalkyl group, non-substituted C_6 to C_{30} arylalkyl group, substituted C_6 to C_{30} hetero-arylalkyl group, non-substituted C_6 to C_{30} hetero-arylalkyl group, substituted C_6 to C_{30} aryloxy group, non-substituted C_6 to C_{30} aryloxy group, substituted C_6 to C_{30} hetero-aryloxy group, and non-substituted C_6 to C_{30} hetero-aryloxy group, or adjacent two of R_{31} to R_{38} form a fused aromatic ring of C_5 to C_{30} ,

wherein in Formulas 4a and 4b, n is an integer of 1 to 3, and L is represented by Formula 5:

[Formula 5]

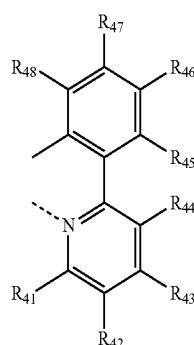

wherein each of R_{41} to R_{48} is independently selected from the group consisting of hydrogen, deuterium, tritium, halogen, substituted C_1 to C_{30} alkyl group, non-substituted C_1 to C_{30} alkyl group, cyano group, substituted C_3 to C_{30} cyclo-alkyl group, non-substituted C_3 to C_{30} cyclo-alkyl group, substituted C_3 to C_{30} hetero cyclo-alkyl group, non-substituted C_3 to C_{30} hetero cyclo-alkyl group, substituted C_5 to C_{30} aryl group, non-substituted C_5 to C_{30} aryl group, substituted C_5 to C_{30} heteroaryl group, non-substituted C_5 to C_{30} heteroaryl group, substituted C_6 to C_{30} arylalkyl group, non-substituted C_6 to C_{30} arylalkyl group, substituted C_6 to C_{30} hetero-arylalkyl group, non-substituted C_6 to C_{30} hetero-arylalkyl group, substituted C_6 to C_{30} aryloxy group, non-substituted C_6 to C_{30} aryloxy group, substituted C_6 to C_{30} hetero-aryloxy group, and non-substituted C_6 to C_{30} hetero-aryloxy group, or adjacent two of R_{41} to R_{48} form a fused aromatic ring of C_5 to C_{30} .

10. An organic light emitting display device, comprising:
a substrate;

the organic light emitting diode of claim 6; and
a thin film transistor between the substrate and the organic light emitting diode and connected to the organic light emitting diode.

11. An organic light emitting diode, comprising:
a first electrode;

a second electrode facing the first electrode; and
an organic layer between the first electrode and the second electrode, wherein the organic layer includes the organic compound of claim 2 as a first dopant, and the organic compound of claim 4 as a second host and a dopant.

12. The organic light emitting diode according to claim 11, wherein the first dopant and the second dopant have the same weight %.

13. An organic light emitting display device, comprising:
a substrate;
the organic light emitting diode of claim 11; and
a thin film transistor between the substrate and the organic
light emitting diode and connected to the organic light
emitting diode.

* * * * *

专利名称(译)	有机化合物，以及包括其的有机发光二极管和有机发光显示装置		
公开(公告)号	US20180130953A1	公开(公告)日	2018-05-10
申请号	US15/794632	申请日	2017-10-26
[标]申请(专利权)人(译)	乐金显示有限公司		
申请(专利权)人(译)	LG DISPLAY CO. , LTD.		
当前申请(专利权)人(译)	LG DISPLAY CO. , LTD.		
[标]发明人	SONG IN BUM KIM CHUN KI		
发明人	SONG, IN-BUM KIM, CHUN-KI		
IPC分类号	H01L51/00 C07D491/048 C07D495/04 C07D487/04 C07D403/10		
CPC分类号	H01L51/0071 C07D491/048 H01L51/0072 C07D495/04 C07D487/04 C07D403/10 H01L51/0067 H01L51/5016 H01L27/3244 H01L2251/5384 H01L2251/558 H01L51/5088 H01L51/5056 H01L51/56 H01L51/5072 H01L51/5092 H01L51/001 C07D209/80 C07D209/82 C07D209/86 C07D519/00 C09K11 /06 C09K2211/1007 C09K2211/1011 C09K2211/1029 C09K2211/1059 H01L51/0056 H01L51/5012 H01L51/0085		
优先权	1020160143282 2016-10-31 KR		
其他公开文献	US10651396		
外部链接	Espacenet USPTO		

摘要(译)

本发明提供用于有机发光二极管的有机化合物。有机化合物的一个例子表示为：

